



RULES
FOR
SKERRY CRUISERS
(SQUARE METRE YACHTS)
2013

Contents:

1	GENERAL REGULATIONS	5
1.1	VALIDITY OF THE RULE	5
1.2	CLASSIFICATION CERTIFICATE AND RATING CERTIFICATE	5
1.3	TABLE I. MEASUREMENT OF SQUARE METRE CLASSES	5
1.3.1	<i>Table and maximum and minimum measurements values</i>	6
1.3.2	<i>Sail area and mast</i>	6
1.3.3	<i>Mean breadth</i>	6
1.3.4	<i>Hull regulations</i>	6
1.3.5	<i>Deck camber</i>	7
1.3.6	<i>Trimming and floating</i>	7
1.3.7	<i>Longer ideal length</i>	7
1.4	TABLE II. EQUIPMENT REGULATIONS	8
1.4.1	<i>Cabin</i>	9
1.5	SKERRY YACHTS.....	9
1.6	ADVERTISING.....	9
1.7	HULL 55-150 SQM	9
2	BUILDING REGULATIONS FOR SKERRY CRUISERS	10
2.1	CLASSIFICATION	10
2.2	A CERTIFICATE AND SURVEYS	10
3	BUILDING REGULATIONS FOR WOODEN YACHTS	11
3.1	CONSTRUCTION UNDER SURVEY	11
3.2	MATERIAL.....	11
3.3	CONSTRUCTIONAL PARTS AND THEIR DIMENSIONS.....	11
3.3.1	<i>Keel, stem, sternpost, horn timber, mast foot and rudder (Table III)</i>	11
3.3.2	<i>Frames and floors (Tables IVa and IVb)</i>	12
3.3.3	<i>Deck beams, beam clamps, bilge stringers and knees (Tables III and V)</i>	13
3.3.4	<i>Planking and deck (Table III)</i>	14
3.3.5	<i>Bolts, rivets and screws (Table VI)</i>	14
3.4.1	TABLE III. PLANKING, DECK, KEEL, STERNPOST, HORN TIMBER, RABBET, RUDDER STOCK, BILGE STRINGERS, COAMING AND CABIN	16
3.4.2	TABLE IV A. FRAMES AND FLOORS, WHEN THE YACHT IS BUILT ONLY ON BENT FRAMES	17
3.4.3	TABLE IV B. FRAMES, FLOORS AND COUNTER FRAMES, WHEN THE YACHT IS BUILT ON SOLID STEEL FRAMES WITH TWO BENT FRAMES IN BETWEEN	18
3.4.4	TABLE V. DECK BEAMS, HORIZONTAL AND VERTICAL KNEES	19
3.4.5	TABLE VI. BOLTS, RIVETS AND SCREWS.....	20
4	CLASSIFICATION AND REGULATIONS FOR THE BUILDING OF YACHTS OF FIBREGLASS REINFORCED PLASTIC	21
4.1	PROCEDURE FOR CLASSIFICATION	21
4.2	CONSTRUCTION UNDER SURVEY	21
4.3	MATERIALS, PREMISES AND GENERAL WORKMANSHIP	22
4.3.1	<i>Manufacturing standards</i>	22
4.3.2	<i>Execution of the work</i>	22
4.3.3	<i>Hand-layering</i>	23
4.3.4	<i>Detail design</i>	23
4.3.5	<i>Joints</i>	23
4.3.6	<i>Riveted and screwed joints</i>	23
4.4	DIMENSIONS OF REINFORCED PLASTIC YACHTS	24
4.4.1	<i>General</i>	24
4.4.2	<i>Requirements for the finished laminate</i>	24
4.4.3	<i>Laminate tests</i>	24
4.4.4	<i>Keel strake / Keel sole</i>	24
4.4.5	<i>Floors</i>	24
4.4.6	<i>Transverse strengthening</i>	25

4.4.7	<i>Bilge lamination</i>	25
4.4.8	<i>Deck flanges</i>	25
4.4.9	<i>Hull, deck and superstructure</i>	26
4.4.10	<i>Mast support</i>	26
4.4.11	<i>Fittings</i>	26
4.4.12	<i>Ballast keel</i>	26
4.4.13	<i>Too small weight of the hull</i>	26
4.4.14	<i>Too small weight of the deck</i>	26
4.5	TABLE VII. DIMENSIONS, WEIGHTS AND FLEXURAL RESISTANCE.....	28
5	MAST AND RIG	30
5.1	GENERAL.....	30
5.2	WOODEN MAST FOR 55-150 SQM CLASSES.....	31
5.3	ALUMINIUM MAST FOR 55-150 SQM CLASSES.....	31
5.4	OTHER MATERIAL MASTS FOR 55-150 SQM CLASSES.....	32
5.4.1	REQUIREMENT OF WEIGHT AND CENTRE OF GRAVITY.....	32
5.4.2	DECK STEPPED MAST.....	32
5.4.3	KEEL STEPPED MAST.....	32
5.5	MASTS OF THE 55-150 m ² CLASSES.....	33
5.5.1	WOODEN MAST.....	33
5.5.2	ALUMINIUM MAST.....	33
5.5.3	OTHER MATERIAL MASTS.....	33
5.6	MASTS OF THE 15-40 m ² CLASSES.....	33
5.6.1	FRONT AREA (A).....	33
5.6.2	MAST TOP WEIGHT (MTV).....	33
5.6.3	REGULATIONS TO AVOID UNDESIRABLE DESIGNS.....	33
5.6.4	REDUCTION FOR LOWER SAIL MEASURING HEIGHT.....	34
5.6.5	ROTATING MAST.....	34
5.6.6	UNCOMMON DESIGNS.....	34
5.7	TABLE VIII MAST.....	34
6	MEASUREMENT INSTRUCTIONS	35
6.1	GENERAL REGULATIONS.....	35
6.1.1	<i>Local inspectors and measurers</i>	35
6.1.2	<i>Restrictions</i>	35
6.1.3	<i>Prohibition against taking extra measurements</i>	35
6.1.4	<i>Measuring instruments</i>	35
6.1.5	<i>Report of inspection or measurement</i>	35
6.1.6	<i>Official appeal</i>	35
6.2	MEASURING OF THE HULL.....	36
6.2.1	<i>Marks</i>	36
6.3	AFFIXING OF THE MARKS.....	36
6.4	DISPLACEMENT CONTROL.....	37
6.5	CONTROL OF THE MEASUREMENTS.....	37
6.6	RIG MEASUREMENTS.....	41
6.6.1	<i>Triangle mainsail on a straight mast</i>	41
6.6.2	<i>Triangle mainsail on a bent mast</i>	41
6.6.3	<i>Gaff mainsail</i>	41
6.6.4	<i>Foretriangle</i>	41
6.7	CALCULATIONS OF THE SAIL AREAS.....	42
6.7.1	<i>Triangle mainsail on a straight mast</i>	42
6.7.2	<i>Triangle mainsail on a bent mast</i>	42
6.7.3	<i>Gaff mainsail</i>	42
6.7.4	<i>Additional area on bent spars</i>	42
6.7.5	<i>Additional area of boom height</i>	42
6.7.7	<i>Forestay profiles</i>	42
6.7.8	<i>Unusual sail shapes</i>	43
6.8	SAIL MEASUREMENT.....	44
6.8.1	<i>Restrictions of foresails for the 15 and 22 m²-classes</i>	44

6.8.2	<i>Mainsail width restrictions</i>	44
6.8.3	<i>Battens</i>	44
6.9	TABLE IX SAILS.....	44

1 GENERAL REGULATIONS

1.1 VALIDITY OF THE RULE

This rule was adopted in 1925 and revised in 1930 and 1935, will apply from the 1st March 1996. An application to change or amend the Rating Rule shall be submitted in writing to the Svenska Skärgårdskryssareförbundet (Swedish Skerry Cruiser Association). The application will either be rejected or investigated. Changes to the Rating Rule will come into force after resolution in two following annual meetings and after hearing foreign square meter societies' opinions, and approval by the Swedish Sailing Federation.

1.2 CLASSIFICATION CERTIFICATE AND RATING CERTIFICATE

For a yacht which is built in accordance with these regulations and under specified supervision, and which proved to satisfy the requirements in all respects, the Classifying Board of Svenska Skärgårdskryssareförbundet will issue a classification certificate which is filed. In addition a rating certificate is issued with the validity of 5 years, but with the proviso that no modifications are made. All modifications e.g. according to the ballast keel, trimming which necessitates moving the marks, should take place under supervision of the Classifying Board. If marks are moved, the classification certificate shall be supplied with the new specifications.

When the period of the rating certificate's validity has expired, this can, after a thorough survey, be renewed for a period that the Classifying Board may decide depending upon the condition of the yacht, but not for a period of longer than 5 years. If the yacht under survey no longer complies with the following constructional rules, a rating certificate will not be issued until the yacht complies with the regulations, or the necessary strength has been achieved by means of approved repairs, e.g. cracked frames replaced or doubled, defective bottom floors replaced or additional ones inserted, etc.

1.3 Table I. MEASUREMENT OF SQUARE METRE CLASSES

<i>Sail area</i> (S — see 1.3.2)	Sqm	Class sqm.								
		15	22	30	40	55	75	95	120	150
<i>Ideal length</i> (L_i — see 1.3.4 and 1.3.7), measured at the points where h_i intersects the hull in the midship plane on the outer side, table value	m	6.50	7.80	9.10	10.50	12.20	14.10	15.80	17.70	19.70
<i>Displacement</i> (W_i — see 1.3.7) table value	kg	790	1 320	2 000	2 940	4 510	6 840	9 380	12 830	17 800
<i>Mean breadth at main section</i> (bm_i — see 1.3.3 and 1.3.7) The main section is defined as the transverse plane at the maximum mean breadth table value	m	1.46	1.66	1.86	2.05	2.29	2.56	2.78	3.01	3.26
<i>Freeboard</i> (F_i — see 1.3.6 and 1.3.7), measured on the main section, from h_0 to the upper edge of the covering board on the sides of the yacht table value	m	0.40	0.45	0.50	0.57	0.67	0.80	0.90	1.00	1.10
<i>Sum of the freeboards</i> ($F_r + F_a$), measured from h_0 to the upper edge of the covering board, at fore and aft ends of L_x . The measurement shall be at least $2 F_i$ table value increased according to 1.3.7 by...	m	0.100	0.118	0.136	0.156	0.182	0.212	0.238	0.266	0.296
<i>Length of keel</i> (K_i), to be measured externally, where a horizontal plane situated at a distance $h_i + F_i$ (table values) below HP1 intersects the hull in the midship plane.	m	1.60	2.00	2.30	2.60	3.00	3.50	3.90	4.40	4.90
<i>Horizontal plane 1</i> : (h_0) height above horizontal plane 0	m	0.13	0.15	0.18	0.21	0.24	0.28	0.31	0.35	0.39
<i>Vertical plane 1</i> : distance (a_1) from midship plane	m	0.18	0.21	0.23	0.26	0.29	0.32	0.35	0.38	0.41
<i>Vertical plane 2</i> : distance (a_2) from midship plane	m	0.61	0.70	0.78	0.86	0.96	1.07	1.17	1.27	1.37
<i>Minimum of height</i> (h_1) from inside of planking to h_0 , measured at main section in vertical plane 1	m	0.40	0.48	0.55	0.63	0.74	0.86	0.97	1.08	1.20
<i>Minimum of height</i> (h_2) from inside of planking to h_0 , measured at main section in vertical plane 2	m	0.19	0.23	0.27	0.31	0.36	0.42	0.47	0.52	0.58

1.3.1 Table and maximum and minimum measurements values

- X_i represents table value
 X_x represents maximum or minimum value
 X_m represents measured value

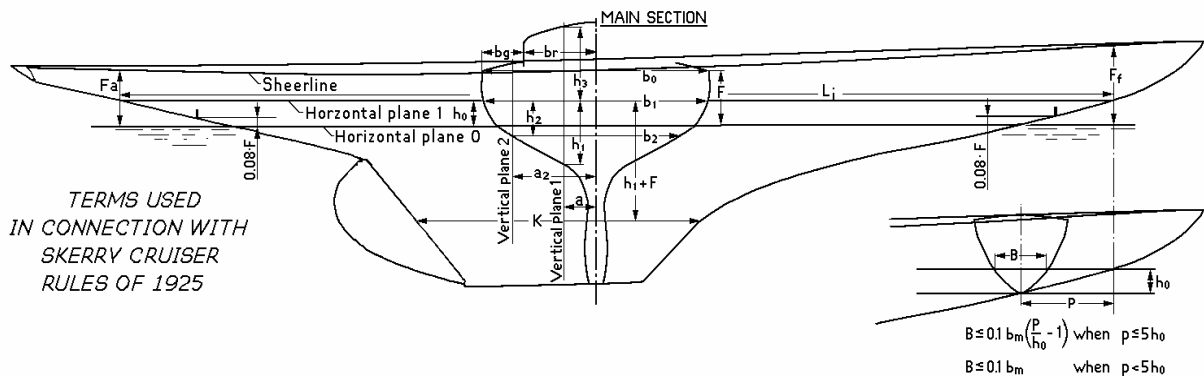

Figure 1 (Designations and measurements)

1.3.2 Sail area and mast

The sail area is measured according to the measurement instructions. The mast may be straight or permanently bent, the curvature may extend over the whole mast or part of it.

1.3.3 Mean breadth

$bm_m = \frac{b_0 + 4b_1 + b_2}{6}$, where b_0 , b_1 and b_2 are breadth measurements on the inside of the main section; b_0 immediately

below the covering board, b_1 in horizontal plane 1, and b_2 at a distance h_2 (table value) below horizontal plane 1. However, b_0 shall not be less than b_1 .

Horizontal plane 1 is situated a distance h_0 (see Table 1) above horizontal plane 0, which shall touch the lower edge of the freeboard marks on the main section. These marks, one on the starboard and one on the port side, shall be affixed in accordance to the designer's or owner's instructions and shall be the basis of the measuring.

Horizontal planes 0 and 1 shall be at right-angles to both the midship plane and the main section, both being equally arranged right-angled to each other.

1.3.4 Hull regulations

Regulations to avoid undesirable designs:

1.3.4.1 In the fore-body of the yacht, the bow width measured externally (B) in horizontal plane 1 on a frame section ¹ (where is footnote for ¹?) through a point where horizontal plane 0 intersects the outside of the hull, shall

not exceed $0.1 \times bm_m \left(\frac{p}{h_0} - 1 \right)$,

when p is equal or smaller than $5 h_0$. When p is greater than $5 h_0$, then B shall not exceed $0.4 bm_m$.

p is the horizontal distance between the frame section and the point where horizontal plane 1 intersects the hull outside, at the forward end of L_x . (See Figures 1 and 14)

1.3.4.2 No point in any frame section may be situated lower than the section's external point of intersection with the midship plane.

1.3.4.3 No point below horizontal plane 1 is allowed to be situated aft of a point where horizontal plane 1 intersects the outside of the hull (L_x 's aft end).

1.3.4.4 If there are any irregularities in the lines of the yacht in the area where measurements are to be taken, the Classifying Board is entitled to determine the method of ascertaining these measurements, in order to fulfil the requirements of the Rating Rule.

¹Frame sections means each vertical athwartship section parallel to the main section.

1.3.4.5 No concavity is permitted in the hull's surface outside a box defined by the inflexion point of the stem and the aft trim mark and sideways by a vertical plane situated halfway between vertical planes 1 and 2.

1.3.4.6 The length of the keel over the K measurement shall not be shorter than K_m . The front edge of the keel shall be swept backwards.

1.3.5 Deck camber

The deck shall in the intersection of the midship plane and the section with the largest breadth in the deck have a height corresponding to 1/25 of the breadth over the freeboard F. The assumed midship curvature shall extend to the ends of the yacht, at the transom stern the deck shall have camber according to the beam jig.

Deck camber, sheer and freeboard shall however be free, but no point on the deck is allowed to be situated lower than that regulated above.

1.3.6 Trimming and floating

When racing, the yacht in fresh water without crew but with the specified equipment onboard, shall not lie deeper than as to permit the lower edges of the freeboard marks lying still visible above the water level, or just touching it. Trimming by the bow or stern will be permitted as far as the points where a horizontal plane situated at the distance of $0,08 \times F_i$ over horizontal plane 0 intersects the hull outside.

1.3.7 Longer ideal length

If the value of the ideal length L_x increases the table value L_i then the following values shall be increased:

1.3.7.1 Displacement

The displacement (W_x) to at least $W_i \times \left(\frac{L_x}{L_i} \right)^2$, where W_i is the value from Table 1

1.3.7.2 Mean breadth

The mean breadth (bm_x) at least $0.1 \times (L_x - L_i)$ more than the table value bm_i .

1.3.7.3 Freeboard

The freeboard (F_x) on the main section with at least $0.04 \times (L_x - L_i)$ more than the table value F_i .

1.3.7.4 Length of keel

The length of keel (K_x) to at least $K_i \times \frac{L_x}{L_i}$, where K is the table value.

1.4 Table II. EQUIPMENT REGULATIONS

		Class sqm									
		15	22	30	40	55	75	95	120	150	
Hull:											
<i>Length of cabin</i> (L_i) in vertical plane 1, measured internally	at least	m	1.50	1.70	2.00	2.30	2.70	3.20	3.70	4.20	—
<i>Width of cabin</i> (b_i) within at least half the length of L_i , table value, measured internally	at least	m	0.98	1.00	1.10	1.20	1.35	1.50	1.65	1.80	—
<i>Height</i> (h_3) of the cabin measured from horizontal plane 1 to the underside of the cabin or deck, within $\frac{3}{4}$ of the length of L_i (table value) in vertical plane 1	at least	m	0.55	0.58	0.68	0.78	0.90	1.00	0.90	0.80	0.70
<i>Gangway width</i> (b_g) outside the cabin superstructure or cockpit coaming	at least	m	0.25 ²⁾	0.31	0.35	0.39	0.43	0.48	0.54	0.60	—
<i>The maximum area of open cockpits</i> within the cockpit coaming ¹⁾		m ²	1.50	1.80	2.20	2.70	³⁾	³⁾	³⁾	³⁾	³⁾
<i>Cockpit coaming</i> , mean height ⁴⁾	at least	m	0.12	0.12	0.13	0.14	—	—	—	—	—
<i>Fixed pump</i> , of adequate size, number	at least		—	—	—	1	1	1	1	1	1
Permanent furnishings:											
<i>Berths in the cabin:</i>											
Number	at least		2	2	2	3	4	4	5	6	6
Length	at least	m	1.85	1.85	1.85	1.90	1.90	1.90	1.90	1.90	1.90
width at the middle	at least	m	0.50	0.55	0.55	0.60	0.65	0.65	0.70	0.70	0.70
<i>Berth in the forepeak:</i> ⁵⁾											
Number	at least		—	—	—	1	1	1	2	2	2
Length	at least	m	—	—	—	1.80	1.85	1.85	1.85	1.85	1.85
width at the middle	at least	m	—	—	—	0.50	0.55	0.55	0.55	0.60	0.60
<i>Bulkheads and floorboards</i> , thickness	at least	mm	12	12	12	13	13	13	14	14	14
<i>Lockers</i> , enclosed, total cubic measurement	at least	m ³	—	—	—	—	0.50	0.70	0.90	1.10	1.30
<i>Kitchen</i> , in separate room, number	at least		—	—	—	—	—	—	—	1	1
<i>WC</i> , in a separate room with at least 0.65 m ² at the sitting level, and wash basin, number of each	at least		—	—	—	—	—	1	1	1	1
<i>Water cisterns</i> , enclosed, total cubic measurement.	at least	litres	—	—	—	—	—	75	100	125	150
Equipment:											
<i>Anchors</i> , number	at least		1	1	1	1	1	2	2	2	2
<i>Weight of anchor No 1</i> , when chain is used	at least	kg	—	13	15	18	22	28	34	40	50
" " " " 1, " rope " "	at least	kg	15	15	17	—	—	—	—	—	—
" " " " 2	at least	kg	—	—	—	—	—	15	20	25	30
<i>Anchor chain</i> , length	at least	m	—	30	35	45	55	65	75	85	95
" " , link diameter	at least	mm	—	4	5	6	7	8	9	10	11
<i>Anchor rope</i> , length	at least	m	25	30	35	—	—	—	—	—	—
" " , breaking load	at least	kN	10	12.5	15.6	—	—	—	—	—	—
<i>Towing rope</i> , length	at least	m	20	30	35	45	55	65	75	85	95
" " , breaking load	at least	kN	7.5	12.5	15.6	18.9	22	25.8	33.5	37.3	41.4
<i>Anchor capstan</i> , number	at least		—	—	—	—	—	—	1	1	1
<i>Maximum crew whilst racing</i> : Number			3	3	4	5	5	6	7	8	9

¹⁾ If L_i is increased to a higher value: L_x , then the maximum open cockpit area may be increased to: $(L_x \times b_x) / (L_i \times b_i)$

²⁾ Measured at the aft end of the cabin, and further aft the width may be gradually decreased to 0.21 m.

³⁾ The 55-150 sqm classes shall be equipped with self-bailing cockpits.

⁴⁾ Then the freeboard height F_m is higher than F_x it is allowed to reduce the height of the coaming with: $(F_m - F_x) / 2$. However, the height of the coaming may at no point be lower than half of the table value.

⁵⁾ A number of extra berths in the cabin may replace these in the forepeak.

For each person on board there shall be a life-jacket according to the special regulations.

Equipment that is mandatory shall be on board whilst racing, and specified permanent furnishings, berth, floorboards etc, shall be carried.

1.4.1 Cabin

No part of the deck, the cabin coaming or the cabin roof is allowed to be inside the planes which connect the measuring points, prescribed by l_r and b_r , with the surface where h_3 shall be kept.

If the freeboard height F_m is higher than F_x (the given minimum value), it is allowed to measure the mentioned measuring points in a plane situated $F_x - h_0 + b_0 / 25$ above horizontal plane 1.

If the board finds it necessary supplemental drawings be required, showing how the measurements have to be controlled.

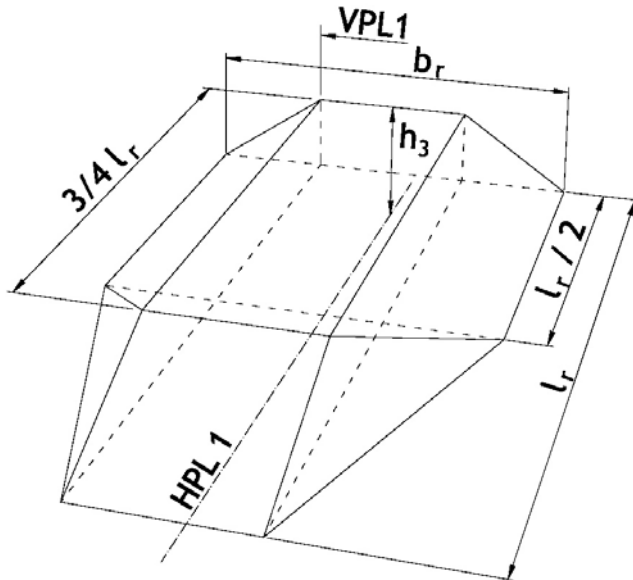

Figure 2 (Cabin)

1.5 SKERRY YACHTS

In accordance with the regulations provisions for the 15 and 22 m² classes, yachts may also be built without cabin and permanent furnishing, and are then designated Skerry yachts.

The cockpit area in these is restricted to 2.00 and 2.50 m² respectively.

Skerry yachts compete in separate classes.

1.6 ADVERTISING

Advertising according to category C is permitted.

1.7 HULL 55-150 sqm

In the 55-150 m² classes may the hull, the deck and strengthenings be lighter constructed than built according regulations of recognized classifying society (Lloyds, Veritas etc) or equivalent calculations. The construction shall at least fulfil strength regulations of table VII.

The reduced weight of the hull, the deck and strengthenings shall be compensated by permanent furnishings of at least the same weight.

The minimum displacement of the yacht is calculated according 1.3.7 and the weight of the ballast keel is allowed to be as most 50% of that. The ballast keel shall be weighed.

The designer supplies with strength and weight calculations and with a list of stipulated permanent furnishings, extra furnishings and equipment.

The permanent equipment shall be stated in the rating certificate.

2 BUILDING REGULATIONS FOR SKERRY CRUISERS

2.1 CLASSIFICATION

In order to be able to sail in races, a yacht belonging to one of the approved classes shall fulfil the stipulated measurements, furnishing, equipping and building specifications and possess a pertinent certificate issued either by a Classifying Board appointed by a national authority or by a recognised classification association.

Such a board, appointed by a national authority, shall consist of at least three persons. The board is responsible that the building regulations are fulfilled. To this end, the board should be sent drawings (copies) in triplicate in good time before the building begins, containing:

Longitudinal and transverse sections showing the longitudinal and transverse structures of the Skerry Cruiser, including bolts, rivets and alike, as well as deck superstructures and cockpit, including necessary dimensions and measuring instructions such as the position of horizontal planes 0 and 1, and the main section.

Deck plane showing deck beams, shelves, cabin structures, cockpit as well as the arrangement of knees, channel plates and other structures, including necessary dimensions.

Rigging drawing showing dimensions (strength) of spars, shrouds, rigging screws etc., including necessary dimensions and measuring instructions.

The calculation of the displacement showing that the yacht satisfies the displacement requirements, as well as details of anchor, chain, rope and weight of the ballast keel and its maximum width against the wooden keel.

The checking of the board's ruling may be assigned to a local inspector appointed by the board.

A scale shall be shown on all drawings.

Other drawings that the Classifying Board finds necessary will be required.

2.2 A CERTIFICATE AND SURVEYS

A yacht built and approved in accordance with the regulations shall be issued with a certificate showing that the yacht satisfies the requirements in accordance with the pertinent class.

All modifications or re-trimmings shall take place under control of the Classifying Board.

If necessary, a final survey shall be carried out when the yacht is launched and rigged.

The *purchaser* (owner) or builder of the yacht shall in due time notify the board or the local inspector when the mentioned above can be conveniently undertaken.

Survey when the five year period has expired, shall be carried out ashore. The surveyor shall as far as possible make sure that the yacht satisfies the requirements in accordance with the pertinent class.

3 BUILDING REGULATIONS FOR WOODEN YACHTS

3.1 CONSTRUCTION UNDER SURVEY

The building of a new yacht shall be under survey of the Classifying Board:

- 1) when the keel, stem, stern and frames (or moulds) are in place, but before the planking of the hull commences.
- 2) when the hull is planked, with deck beams and shelves in place, but before laying of the deck planks has commenced.
- 3) when the yacht is completed, but before she has been launched, when the mast and rig shall also be surveyed and the total displacement shall be confirmed through weighing.

3.2 MATERIAL

All of the wood to be used shall be of good quality, well seasoned, free from fissures, large knots or rot, and shall be of prescribed scantlings. Only such well seasoned woods as are suited for the intended purpose shall be used. Other materials than those enumerated below shall only be used with the consent of the board.

Where constructional parts enumerated below are made of wood, the keel, stem, sternpost, stemson, mast foot floors, deck knees and rudder post, shall be made of oak or an equivalent type of wood (specific gravity of at least 0.65).

For bent frames oak or elm shall be used, in accordance with the dimensions quoted in the tables.

For hull planking, deck beams, shelves and deck planking, pine, pitch pine, Oregon pine or mahogany are approved with a specific gravity at least 0.50. When other types of wood which are not equivalent to the above mentioned or which have a lower specific gravity are used, an increase in the linear dimensions in accordance with the tables, which at least corresponds to the reduction in specific gravity shall be made, which increase is laid down for the following types of wood as: light pine 5 %; fir and spruce 10 %; cedar and light mahogany 15 %.

When plywood is used, it shall be of good and water-resistant quality and of *first grade*; the face veneer shall have a proper and solid surface free from visible defects.

Where steel is used for constructional parts, it shall meet the quality generally prescribed for building to classification.

Where stainless steel is used, it shall be austenitic and contain molybdenum i.e. SIS 2343

When materials and methods of construction, other than prescribed in these regulations and tables are used, a yacht may nevertheless be classified if the board finds that the alterations do not reduce the strength of the yacht.

In this connection it is pointed out that if frame and beam spacing greater than those quoted in the table are used, stronger longitudinal and transverse joints shall be used.

If smaller frame or beam spacing is used, no reduction in planking, deck or longitudinal joints is approved, but transverse joints may be reduced, but then areas and moments of resistance to bending, measured per metre length of the boat, shall be at least as great as for those transverse joints prescribed in the tables.

3.3 CONSTRUCTIONAL PARTS AND THEIR DIMENSIONS

The dimensions of the different structural parts as quoted in the tables generally apply amidships for two-thirds of the length of the yacht in horizontal plane 1 (L_i). For yachts with greater length L_x than the table value L_i , specifications apply to L_x where L_i is quoted. Forward and aft of this part of the yacht, dimensions of certain constructional part may be reduced to the values given in the tables for the next smaller class; others may be reduced to a value prescribed below. For frames and beams the first given figure represents the height in the transverse section.

3.3.1 Keel, stem, sternpost, horn timber, mast foot and rudder (Table III)

3.3.1.1 Keel

The dimensions of the keel quoted in the tables are minimum dimensions in a midship section; here, the fabricated part of the keel shall also at least contain the width dimension of the table; at the ends, the keel can be reduced to the dimension of the stem.

3.3.1.2 Stem

The stem shall have at least those dimensions quoted in the table, at the forward end of L_0^2 and at the mast. From the forward end of L_0 , the width and the height of the stem shall be successively increased to the mast. At none of the points is the effective cross-sectional area of the stem (obtained after deducting the rabbet etc.) allowed to be less than 75 % of the product of the table values for height and width.

The width of the stem below deck, measured inside the planking, shall not be less than 60 % of the table value for the width at the forward end of L_0 . The outside planking shall be well fastened and the rabbets should be of adequate size (see table). If the stem is to be scarfed, such a scarf shall be arranged at a sufficient height above horizontal plane 0. A stem scarf shall be executed as a hook scarf or a quoin scarf. Keel and stem may be constructed in one piece.

3.3.1.3 Sternpost

The width of the sternpost (mean value athwartships dimension) is to be measured at the horn timber; the height of the stern post shall also be adequate.

The sternpost may be reduced aft to the thickness of the rudder blade.

3.3.1.4 Horn timber

The horn timber shall be well connected to the sternpost and the effective cross-sectional area (i.e. the area after deduction of the rudder port and rabbeting etc.) shall not be less than the table value.

When the horn timber in the way of the rudder port is fitted with filling chocks, the combined effective cross-sectional area shall be at least 20 % greater than the table value. The dimensions of the horn timber may be gradually reduced towards the stern, so that at the after point of L_0 the table values are complied with; at the sternpost point, the height of the horn timber measured inside the planking may be reduced to twice the thickness of the planks and the width to 80 % of that prescribed at the aft end of L_0 . At the aft end of L_0 the effective cross-sectional area shall not be less than 75 % of the product of the table values for height and width.

3.3.1.5 Mast foot

The mast foot, arranged on the floors and of approved design, shall be fitted for a length of at least 15 % of L_i , depending upon the arrangement of the floors and the design of the mast step.

When the mast is placed on deck, the mast shall be supported by an arrangement dimensioned for a pressure force corresponding to twice the displacement.

3.3.1.6 Rudder

The rudder shall with its leading edge follow the sternpost down to at least 85 % of the greatest draught, and independent rudders are consequently prohibited.

3.3.1.7 A centreboard

A centreboard is prohibited.

3.3.2 Frames and floors (Tables IVa and IVb)

3.3.2.1 The dimensions for frames given in the tables apply to amidships within two-thirds of length L_x . Forward and aft of this length frames may be reduced in dimensions in accordance with the table values for the next smaller class. For the smallest class according to Tables IVa and IVb, no reduction can be made.

3.3.2.2 All yachts in the 15 – 30 m² classes shall have at the chain plates, if they are built only on bent frames, two heavy frames of steel or bent frames of dimensions quoted in Table IVa. All yachts from and including 40m² classes and upwards should have at least two steel frames reinforced with angle irons of dimensions specified for counter-frames at the chain plates. Such a counter-frame is riveted to the frame, which it shall follow from the deck and along the upper edge of the floor or well displaced ribbed floor.

3.3.2.3 All bent frames shall be made in one length and with the same width and height from keel to deck.

² L_0 = the length of the yacht in horizontal plane 0, measured outside in the midship plane.

3.3.2.4 All lying flanges of angle-iron frames and also bent frames where practicable, should be carefully let into and fixed in the keel and stem with screws.

3.3.2.5 In the keel section bent frames, without being reinforced with a steel frame or a floor, shall have internal radii of curvature of at least six times the height of the frame.

3.3.2.6 Those dimensions for wooden and metal floors quoted in the tables (see Figures 3-5) apply to ordinary floors, and not to those where a keel bolt passes through, for which case a separate specification exists.

3.3.2.7 The height dimension for wooden and metal floors quoted in the tables, shall be measured within two-thirds of the length L_i from the top of the floors to the vertical plane 1. The top of the floor in the midship plane may, for sharp or V-shaped midship sections, lie a maximum of one-sixth of the table value for the length of the arms, lower than the top of the floor in vertical plane 1. However, within two thirds the length L_i , the height of a wooden or metal floor in the midship plane above the keel, stem or horn timber, shall amount to at least one-fifth of the table value for the length of the arms, corresponding heights forward of two-thirds of L_i shall be at least a quarter and aft of two-thirds of L_i at least one-fifth of the prescribed length of arms. The width dimension (measured in fore and aft direction) given in the tables shall comply in the midship plane, but the width may be reduced gradually to the ends to 80 % of the table value within two-thirds of the length L_i in vertical plane 1. The arm length of the floors specified in the tables and measured horizontally, shall be apparent within two-thirds of length L_i , fore and aft, the arm length measured along the planking, shall be at least one-third of the length of the frame. Where a ballast keel bolt passes through a wooden floor, the floor shall always have a width of at least three times the diameter of the bolt. For an angle-iron floor, necessary allowance shall be made for the bolt hole by riveting on or welding on a reinforcing plate or bracket of adequate strength. The arm length of floors which a keel bolt passes shall be increased by 10 % of the table value. For such wooden floors, the dimensions in vertical plane 1 shall also be increased by 10 % of the values specified for width and height in the table. The floors at the mast foot shall be well fastened to the latter and be thicker than the floors specified at the corresponding positions in the tables. Where a floor is fitted next to a bent frame, it should be attached both to the frame and to the planking. Where, as prescribed in Table IVb, a stiffening angle bar is specified for floors on angle-iron frames, the arm length of the stiffening angle shall be at least 25 % larger than the arm length of the floor, from the rudder port through the horn timber to the front edge of the mast foot. The projecting section of the stiffening angle bar shall be riveted to the frame.

3.3.2.8 Floors shall be arranged in all angle-iron frames amidships within two-thirds of the length L_i in accordance with the tables and specifications in paragraphs 3.3.2.6 and 3.3.2.7. Fore and aft, floors can be made of angle-iron and of the frame dimensions of the class.

3.3.2.9 Beyond the after end of length L_i , the floors in the stern can be dispensed if the frames are fitted in one length from deck to deck, but in this case the dimensions of the horn timber should be adequately increased.

3.3.2.10 From and including the 30 m² class and upwards, an extra floor is to be fitted between each iron-angle bar frame, from the rudder port through the horn timber to the front edge of the mast foot.

3.3.2.11 When a yacht is built only on bent frames, floors shall be fitted on every other frame within two-thirds of length L_i . Fore and aft of this point one floor at every third frame will suffice.

3.3.3 Deck beams, beam clamps, bilge stringers and knees (Tables III and V)

3.3.3.1 Continuous deck beams of greater length than half the largest deck beam of the yacht shall comply with the dimensions given in Table V.

Shorter continuous beams and half-beams may comply with the dimensions given in Table V for the next smaller class.

3.3.3.2 Decks beams at the mast, where halyards are fastened, shall be connected to the mast foot, floor or mast, by means of wooden or steel struts. The same applies to the sheave holes for jib or foresail attachment on deck, in which case the deck beam underneath shall be connected to the stem.

3.3.3.3 Where one or two deck beams are cut off, at least one or two hatch beams should be fitted, with dimensions according to Table V. When more than two deck beams are cut off, heavy beams should be fitted, with dimensions according to Table V.

In addition, a heavy beam of at least the dimensions of the hatch beams, shall be located at the jib stay.

3.3.3.4 Deck beams shall be set in beam clamps, and the covering board is attached as in Figure 7. The covering board is allowed to be successively reduced to 90 % of the width specified in Table 3 fore and aft of two-thirds of L_i .

If a sufficient number of extra horizontal knees (see the number prescribed in Table V) are fitted, the width of the

covering board may be reduced to 90 % of the table value, and fore and aft of two-thirds of L_i to 80 % of the table value, and fore and aft of two-thirds of L_i to 80 % of the table value.

When a deck includes a plywood layer of at least 6 mm, the demand for horizontal knees is deleted. When the whole deck is of plywood the covering board can be excluded.

3.3.3.5 Forward and aft of three-quarters of L_i , beam clamps can gradually be reduced to 75 % of the area specified in Table III.

3.3.3.6 In all yachts in the 95, 120 and 150 m² classes bilge stringers shall be fitted. Their area outside of three-quarters of L_i , can be gradually reduced at the end of the yacht to 75 % of the midship area.

3.3.3.7 When there is a scarf in the covering board, beam clamps or some of the upper planks in the area of one-sixth of L_i in the way of the chain plates, a fishplate shall be fitted within the area quoted, riveted to the beam clamp and the deck beams with an area amidships constituting half the beam clamps area. This fishplate may be reduced in the ends to 75 % of the largest area.

3.3.3.8 Vertical knees in at least the number and dimensions quoted in Table V shall be fitted, and shall be located at the jib stay frame, chain plate, forward and after end of the cabin and at the after end of the cockpit. Knees shall be attached both in deck beams and frames. These deck beams shall be arranged so that they rest on frames even before the knees are located (see Figure 7).

3.3.3.9 When the deck beam at the aft end of the cabin is not made continuous, a beam of the same strength shall be located in its place lower down, but not below horizontal plane 1. This beam is connected to frames by means of knees and an extra clamp spanning at least three frames.

From and including the 40 m² class upwards, at least two heavy beams in accordance with dimensions specified in the tables are installed at the after end of the cabin, and preferably at the beam spacing specified. When these beams are not made continuous for the 40 m² class, beams of the same strength should be located in their stead lower down, but not below horizontal plane 1, and connected to frames in a manner similar to that described above.

3.3.3.10 From and including the 75m² class and upwards, there shall be a straight line connection from the covering board to floor or a counter-frame in at least two places on each side.

3.3.4 Planking and deck (Table III)

3.3.4.1 When the deck or cabin roof is lined with canvas which is painted, a reduction of 2 mm in the thickness quoted in the table is allowed.

3.3.4.2 Butt scarfs in adjoining planks shall not be located closer together to one another than 1.5 m. When there is a plank in between, the distance may be reduced to 1.0 m. When two scarfs are located close to or at the same frame, there must be at least three planks in between the scarfs. Minor modifications may be made in the bow and stern. The scarfs are executed as butt scarfs by means of oak, mahogany or metal strips which shall in length fit between two frames and overlap the adjoining planks with at least the planking thickness (table value) (See Figure 6).

3.3.4.3 Glued scarfs: can be executed as *joint scarfs, horizontal or vertical*. The scarfs shall have a pitch of at least 1 to 5. Scarfs in adjoining planks shall have a dislocation of at least 1000 mm centre to centre. When there is a plank in between the scarfs may be located 750 mm from each other. When there are three planks in between, the location of the scarfs is free.

3.3.5 Bolts, rivets and screws (Table VI)

3.3.5.1 All bolts and rivets passing through timber shall be provided with washers of the same material as the bolt or rivet. Where square rivets or nails are used, a smaller cross-sectional area than for round rivets or nails is not permitted.

3.3.5.2 All bolts, rivets or nails made of steel shall be galvanised, and copper rivets are not allowed in steel structural parts. Rivet or screws in planking shall not be countersunk more than a quarter of the thickness of the plank before plugging or sealing.

3.3.5.3 All floors are to be attached to the keel or stems with through bolts. The number will depend on the width of the keel or stems. For the 15 and 22 m² classes, screws may be used in place of bolts aft of the after end of L_i .

3.3.5.4 Beam clamps are attached within three-quarters of L_i by means one or two rivets respectively in each frame, both angle-iron or bent ribs, and at the ends by at least one rivet in each frame.

3.3.5.5 When ballast keel bolts of steel are used, they shall be well galvanised, and the combined core area A in square centimetres shall be at least in accordance with the formula: $A = 2 \times \frac{V \times h}{b}$

where V is the weight of the ballast keel in metric tons

h is the height of the ballast keel

b is the largest width close to the wooden keel

The tensile strength of the steel (K_j) in the formula is assumed to be 3,500 to 4,000 kg per cm^2 .

For other materials, the combined core area is altered in relation to the tensile strength of the material (K_x) to $A = K_j/K_x$

which, e.g. for copper, means an increase in core area of approximately 50 % compared to steel bolts. It is assumed in the formula that the centre of gravity lies at the half the height. Should the shape of the keel be such that there is an important deviation from this assumption, then allowance shall be made for this.

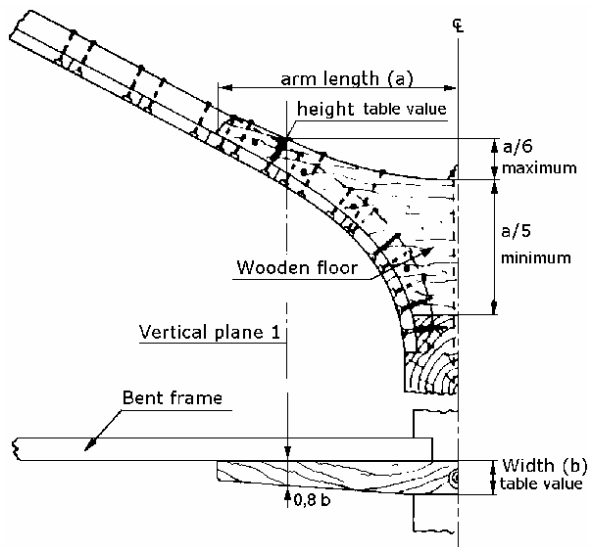

Figure 3 (Timber floor)

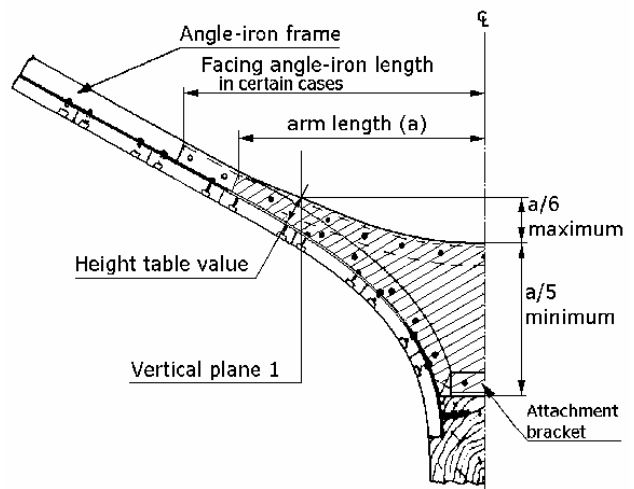

Figure 4 (Angle-iron floor)

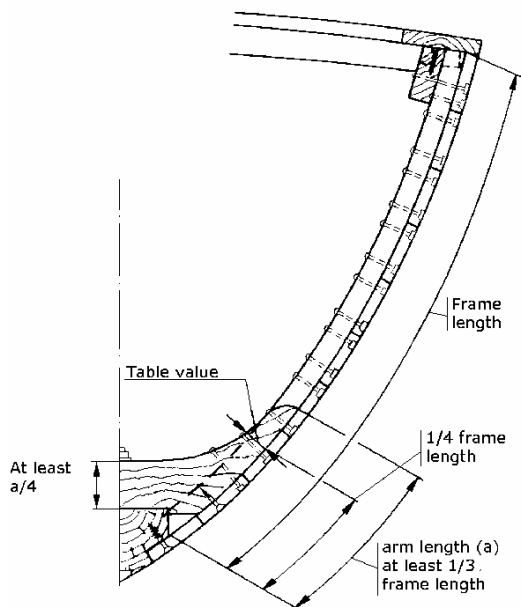

Figure 5 (Timber floor in the fore body)

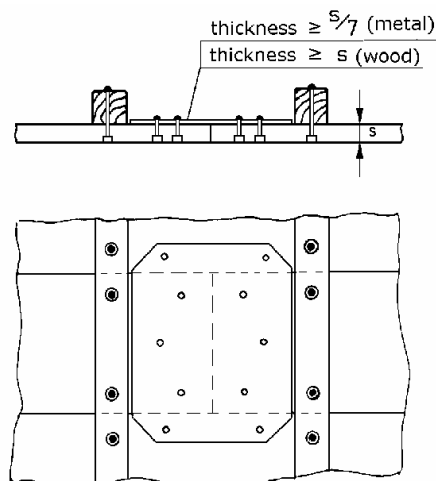

Figure 6 (Planking scarf)

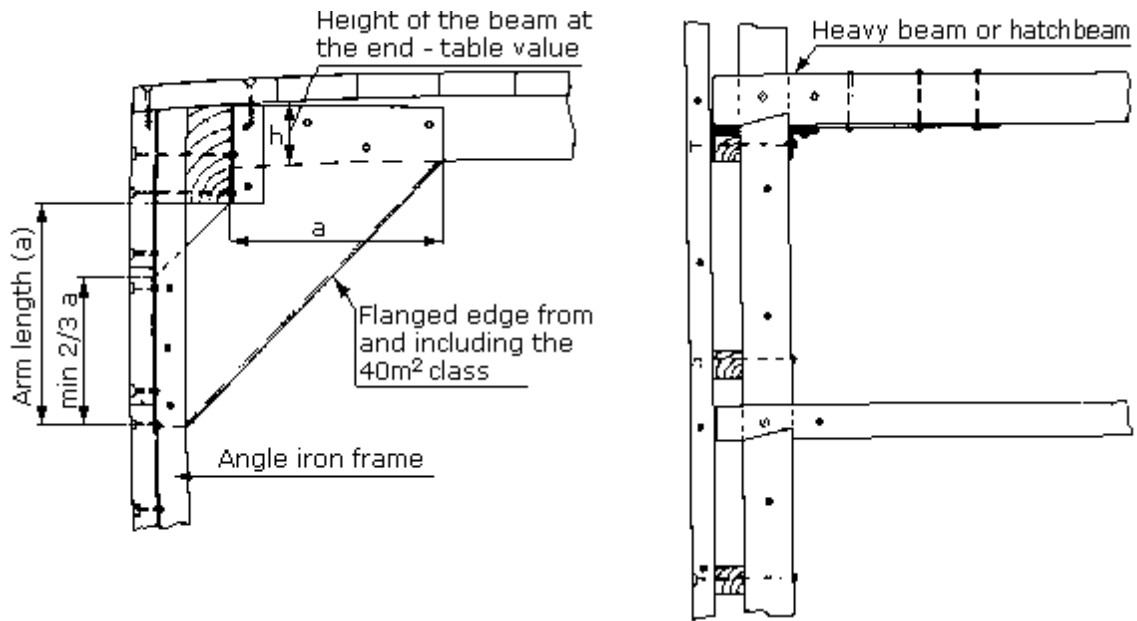

Figure 7 (Metal beam knee and location of covering board screws)

3.4.1 Table III. PLANKING, DECK, KEEL, STERNPOST, HORN TIMBER, RABBET, RUDDER STOCK, BILGE STRINGERS, COAMING AND CABIN

(All dimensions quoted are minimum dimensions.)

		Class m ² .								
		15	22	30	40	55	75	95	120	150
Planking and deck, thickness	mm	14	16	18	20	22	24	27	31	35
Covering board, width	mm	85	95	105	115	125	140	155	170	185
Keel, height×width	mm	70×90	80×110	90×140	100×160	110×190	125×220	140×240	155×260	175×280
Stem at forward end of L ₀ , height×width ¹⁾	mm	70×70	80×80	90×90	100×100	110×110	125×125	140×140	155×155	175×175
stem at mast, height×width	mm	100×80	110×90	120×100	135×110	145×125	160×140	180×150	205×175	230×200
Sternpost at horntimber, height×width	mm	140×35	160×40	180×45	200×50	220×55	240×63	270×71	305×80	350×90
Horn timber at rudder, transverse section area	cm ²	33	43	54	67	81	104	131	160	204
Horn timber at aft end of L ₀ , height×width	mm	50×65	55×75	60×85	70×95	75×105	85×120	100×130	110×145	120×165
Rabbit in keel, width	mm	35	40	45	50	55	62	68	77	87
" " stem	mm	28	32	36	40	44	48	54	62	70
" " sternpost	mm	40	50	54	60	65	75	77	87	97
" " horntimber	mm	28-23	32-25	36-27	40-32	44-35	48-38	54-43	62-50	70-56
(lowest figures apply furthest aft)										
Rudder stock, of timber, diameter	mm	57	60	65	70	78	90	100	115	130
" " of iron bar,	mm	22	24	26	28	30	33	35	40	45
" " of steel tube,	mm	25	25	28	31	34	38	41	44	47
" " of " , thickness	mm	3	4	4	4	5	5	5	6	6
Beam clamp, cross-section area	cm ²	11	17	24	31	42	59	74	94	117
Bilge stringer, cross-section area	cm ²	—	—	—	—	—	—	47	60	75
Coaming & cabin coachlines, cross-section area	cm ²	6	9	13	17	23	32	40	51	64
Cockpit and cabin coaming, thickness	mm	12	14	16	18	20	22	23	—	—
Cabin roof, thickness	mm	14	14	16	18	19	20	21	—	—

¹⁾ L₀ is the length of the yacht, where horizontal plane 0 intersects the hull outside in the middle plane.

3.4.2 Table IV a. FRAMES AND FLOORS, when the yacht is built only on bent frames

(Except frame spacing and spacing between floors, all dimensions quoted are minimum.)

		Class m ² .			
			22	30	40
<i>Frame spacing, centre to centre</i>	mm	167 ¹⁾	167 ¹⁾	167 ¹⁾	167 ¹⁾
<i>Bent frames, height×width, within 2/3 of L_x³⁾</i>	mm	23×25	25×25	28×28	31×31
<i>Bent frames, height×width, fore and aft of 2/3 of L_x³⁾</i>	mm	20×25	23×25	25×25	28×28
<i>Floors, within 2/3 of L_x³⁾, mutual spacing</i>	mm	334 ²⁾	334 ²⁾	334 ²⁾	334 ²⁾
<i>Floors, within 2/3 of L_x³⁾, arm length, measured horizontally</i>	mm	250	280	320	350
<i>Floors of timber, within 2/3 of L_x³⁾, measured from the top of the floor in vertical plane 1 perpendicular to the planking in the section</i>	mm	26	30	33	38
<i>Floors of timber, within 2/3 of L_x³⁾, width, measured fore and aft in the midship plane.</i>	mm	29	33	39	44
<i>Floors of steel, within 2/3 of L_x³⁾, thickness of plate</i>	mm	—	—	3	3
<i>” ” ” ” ” ” ” ”, height measured from the top of the floor in vertical plane 1 perpendicular to the planking in the section</i>	mm	—	—	48	54
<i>Floors of steel, within 2/3 of L_x³⁾: bracket arm</i>	mm	—	—	20×20×3	25×25×3
<i>facing angle-iron, up to</i>	mm	—	—	—	20×20×3
<i>attaching angle-iron, down to</i>	mm	—	—	40×40×4	40×40×4
<i>Floors of timber, fore and aft of 2/3 of L_x³⁾, mutual spacing</i>	mm	500	500	500	500
<i>Floors of timber, fore and aft of 2/3 of L_x³⁾, height, measured perpendicular to the planking in the section at a distance along the planking of 1/4 of the frame length from stem of horn timber.</i>	mm	23	25	28	32
<i>Floors of timber, fore and aft of 2/3 of L_x³⁾, width, measured Fore and aft in the midship plane</i>	mm	24	26	31	35
<i>Floors of steel, fore and aft of 2/3 of L_x³⁾,</i>	mm	20×20×3	25×25×3	25×25×3	30×30×3
<i>Heavy frames by the chain plates:</i>					
Number		2	2	2	2
When of wood, bent frames	mm	23×32	25×36	28×40	—
” ” steel	mm	25×25×3	25×25×3	25×25×3	30×30×3
<i>Floors of steel, on the mentioned steel frames:</i>					
plate thickness	mm	2	3	3	3
facing angle-iron	mm	—	—	20×20×3	25×25×3
attaching angle-iron	mm	30×30×3	35×35×3	40×40×4	40×40×4
height measured from the top of the floor in vertical plane 1 perpendicularly to the planking in the section.	mm	54	65	75	90

1) $167 = \frac{1}{3} \times 500$

2) $334 = \frac{2}{3} \times 500$

3) L_x = length of the yacht in horizontal plane 1, outside measured in the midship plane.

3.4.3 Table IV b. FRAMES, FLOORS AND COUNTER FRAMES, when the yacht is built on solid steel frames with two bent frames in between

(Except frame spacing, all dimensions quoted are minimum.)

	mm	Class m ² .						
		30	40	55	75	95	120	150
<i>Frames of steel</i> , equal spacing, centre to centre	mm	500	500	500	525	560	600	650
<i>Frames of steel</i> , within $\frac{2}{3}$ of L _x , height × width × thickness	mm	25×25×3	30×30×3	35×35×3	40×40×4	45×45×4	50×50×5	60×50×5
<i>Bent frame</i> , within $\frac{2}{3}$ of L _x , height × width	mm	22×25	25×25	30×30	32×40	34×43	36×46	40×50
<i>Counter frames</i> , of angle-iron bars, for steel frames at the chain plates	mm	—	25×25×3	30×30×3	35×35×3	40×40×4	45×45×4	50×50×5
<i>Floors</i> , within $\frac{2}{3}$ of L _x , on each solid frame: thickness of plate the arm length of the plate ¹⁾ height, measured from the top of the frame in vertical plane 1 perpendicularly to the planking in the section. facing angle-iron bar attaching angle-iron bar	mm	3	3	3	4	4	4	5
	mm	320	350	390	440	480	510	550
	mm	50	60	70	80	90	100	110
	mm	—	25×25×3	30×30×3	30×30×4	35×35×4	40×40×4	45×45×4
	mm	40×40×4	40×40×4	40×40×5	50×50×5	50×50×5	55×55×6	65×65×6
<i>Floors</i> , fore and aft of $\frac{2}{3}$ of L _x , on each solid frame, if of steel: thickness height, measured perpendicular to the planking in the section at a distance along the planking of $\frac{1}{4}$ of the frame length from stem or horn timber	mm	2	2	3	3	3	4	4
	mm	40	48	56	64	72	80	88
<i>Floors</i> , fore and aft of $\frac{2}{3}$ of L _x , on each solid frame, if of steel: facing angle-iron bars attaching angle-iron bars	mm	—	—	—	25×25×3	30×30×3	30×30×4	35×35×4
	mm	35×35×3	35×35×4	40×40×4	45×45×4	45×45×4	50×50×5	55×55×6
<i>Floors</i> , fore and aft of $\frac{2}{3}$ of L _x , on each solid frame if angle-iron bars	mm	25×25×3	30×30×3	35×35×3	40×40×4	45×45×4	50×50×5	60×50×5
<i>Extra floors</i> , if of timber: arm length ¹⁾ height, measured from the top of the frame in vertical plane 1 perpendicularly to the planking in the section width, measured fore & aft in the midship plane	mm	320	350	390	440	480	510	550
	mm	30	36	42	50	60	70	80
	mm	38	42	48	55	65	75	85
<i>Extra floors</i> , if of steel: arm length of the floor plate thickness " " " " height, measured from the top of the frame in vertical plane 1 perpendicularly to the planking in the section bracket arm " " length facing angle-iron " " length attaching angle-iron	mm	320	350	390	440	480	510	550
	mm	3	3	3	4	4	4	5
	mm	50	60	70	80	90	100	110
	mm	25×25×3	30×30×3	35×35×3	40×40×4	45×45×4	50×50×5	60×50×5
	mm	480	525	585	660	720	765	825
	mm	—	25×25×3	30×30×3	30×30×4	35×35×4	40×40×4	45×45×4
	mm	—	440	490	550	600	640	690
	mm	40×40×4	40×40×4	40×40×5	50×50×5	50×50×5	55×55×6	65×65×6

¹⁾ Measured horizontally

3.4.4 Table V. DECK BEAMS, HORIZONTAL AND VERTICAL KNEES

(Except beam spacing, all dimensions quoted are minimum.)

		Class m ² .								
		15	22	30	40	55	75	95	120	150
<i>Deck beams</i> , equal spacing centre to centre	mm	250	250	250	250	250	262.5	280	300	325
<i>Deck beams</i> , usually continuous if longer than half the largest deck width: height×width, at the centre of the beam: height×width, at the outboard ends	mm	31×25	33×25	36×27	40×29	45×32	51×36	58×41	66×47	75×54
	mm	25×25	27×25	29×27	32×29	36×32	41×36	47×41	53×47	60×54
<i>Heavy beams</i> : number height×width, at the centre of the beam height×width, at the ends	mm	4	4	4	5	5	5	5-6	5-6	5-6
	mm	45×32	50×36	55×40	60×44	68×48	77×54	87×62	99×70	113×81
<i>Hatch beams</i> : height×width, at the centre of the beam height×width, at the ends	mm	38×28	41×31	45×34	50×37	56×40	64×45	73×51	83×58	94×68
	mm	31×28	33×31	36×34	40×37	45×40	51×45	58×51	66×58	75×68
<i>Vertical knees</i> : number on each side arm length, measured from the inner side and underside respectively of the beam clamp	mm	4	4	4	5	5	5	6	6	6
	mm	125	140	155	170	190	220	250	285	330
<i>Vertical knees</i> , when of: timber, height ¹⁾ ×width ²⁾ , measured at half arm length a) <i>steel plate</i> , thickness b) <i>angle-iron</i> , c) <i>wrought iron</i> , at beam clamps at the ends	mm	54×32	60×36	66×40	72×44	—	—	—	—	—
	mm	2	3	3	3	3	4	4	4	5
	mm	25×25×3	25×25×3	30×30×3	35×35×3	40×40×4	45×45×4	50×50×5	60×60×5	60×60×6
	mm	8×25	10×25	12×25	14×27	16×29	18×32	20×36	22×41	24×47
	mm	6×18	7×18	9×19	11×20	12×22	14×24	15×27	17×31	18×35
<i>Horizontal knees</i> : number on each side arm length, measured from beam or beam clamp, respectively	mm	3	4	4	5	5	6	7	8	9
	mm	120	130	140	150	165	180	200	220	240
<i>Horizontal knees</i> , when of: timber, height ³⁾ ×width ⁴⁾ , measured at half arm length <i>steel plate</i> , thickness	mm	25×31	25×33	25×36	32×40	32×45	32×51	37×58	37×66	37×75
	mm	—	—	—	2	3	3	3	4	4

¹⁾ Athwartship measurement

²⁾ Fore and aft measurement

³⁾ Vertical measurement

⁴⁾ Horizontal measurement

3.4.5 Table VI. BOLTS, RIVETS AND SCREWS

(Except rivets and screws spacing, all dimensions quoted are minimum.)

		Class m ² .								
		15	22	30	40	55	75	95	120	150
<i>Bolts</i> , galvanised or stainless steel, through keel, stems, stern or horn timber: within 2/3 L _x , diameter fore and aft of 2/3 L _x , diameter	mm	8	10	12	12	12	16	16	20	20
	mm	6	8	10	10	12	12	12	16	16
<i>Rivets</i> through planking and frames, number in courses: with a width 71—120 mm " " " 121—170 mm " " " 171—220 mm	mm	2	2	2	2	2	2	2 (1) ¹⁾	2 (1) ¹⁾	2 (1) ¹⁾
	mm	3	3	3	3	3	3	2	2	2
	mm	—	—	—	—	—	—	3	3	3
<i>Rivets</i> through planking and steel frames, galvanised steel, diameter	mm	3.5	4	4.5	5	5	5.5	6	6.5	7
<i>Screws</i> stainless steel, diameter	mm	5	6	6	6	6	8	8	8	8
<i>Rivets</i> through planking and bent frames, copper, diameter	mm	3	3.5	3.5	3.5	3.5	4	4.5	4.5	5
<i>Rivets</i> in steel structures, of galvanised steel: diameter ²⁾ mutual spacing, maximum	mm	4—5	5—6	5—6	6—7	6—8	7—9	8—10	8—11	8—12
	mm	32—48	40—48	40—48	48—56	48—64	56—72	64—80	64—88	64—96
<i>Rivets</i> through stringers, steel frames and planking, galvanised steel, diameter	mm	3.5	4	4.5	5	5	5.5	6	6.5	7
<i>Screws</i> stainless steel, diameter	mm	6	6	6	6	8	8	8	8	8
<i>Rivets</i> through stringers, bent frames and planking, of copper, diameter	mm	4	4.5	5	5.5	6	6.5	7	7.5	8
<i>Rivets</i> through planking and timber floors, of copper, diameter	mm	3.5	4	5	5.5	6	6.5	7	7.5	8
<i>Rivets</i> through planking and bracket arm on extra floor galvanised steel, diameter ³⁾ <i>Screw</i> stainless steel, diameter	mm	3	3.5	4	4.5	5	5.5	6	6.5	7
	mm	5	6	6	6	6	8	8	8	8
<i>Rivets</i> through planking and timber floors or extra steel floors, mutual spacing maximum:	mm	60	70	80	90	100	110	120	130	140
<i>Rivets</i> through vertical knees and beam and frames, number in each, see Figure 6. <i>Rivets</i> through vertical knees and beam: when of copper, diameter " " galvanised steel, diameter <i>Screw</i> stainless steel, diameter	mm	3	3	3	3	4	4	4	4	4
mm	3.5	4	4.5	5	—	—	—	—	—	—
mm	3	3.5	4	4.5	5	5.5	6	6.5	7	7
mm	5	6	6	6	6	8	8	8	8	8
<i>Rivets</i> through horizontal knee and beam or stringer: number in each arm when galvanised steel, diameter " copper, diameter <i>Screw</i> of stainless steel, diameter	mm	2	2	2	2	3	3	3	3	3
	mm	3	3.5	4	4.5	4.5	5	5	5.5	6
	mm	3	4	4.5	5	5	5.5	6	6.5	7
	mm	5	6	6	6	6	8	8	8	8
<i>Wood screws</i> through planking and keel, stems or stern: diameter length mutual spacing ⁴⁾ , maximum	mm	5	5	5.5	5.5	6	6	7	7	7
	mm	32	38	38	44	51	51	64	64	76
	mm	55	55	60	60	60	60	70	70	70
	mm	5	5	5	5.5	5.5	6	6	7	7
<i>Wood screws</i> through covering board: diameter ⁵⁾ length	mm	5	5	5	5.5	5.5	6	6	7	7
	mm	32	32	38	38	38	40	40	50	50

¹⁾ The figures in brackets give the number of rivets in every other frame for fairly small course (71-90 mm).

²⁾ The lower figures apply where minimum thickness of material (average value) occurs.

The higher figures apply where maximum thickness of material (average value) occurs.

Here, steel structure is taken to mean riveted structural parts of steel, e.g. plates with angle-iron, angle-iron with angle-iron, etc.

³⁾ Close to keel, stems, sterns or horn timbers screws (brass, galvanised steel or stainless steel) of least 25 % thicker diameter than the rivets shall be used in lieu

⁴⁾ As far as possible, these screws shall be arranged in zigzag formation.

⁵⁾ The covering board is fixed to the planking, stringers and beams according to Figure 7. The screws through the covering board and planking may be of a smaller diameter if they are placed tighter than the figure drawing shows.

4 CLASSIFICATION AND REGULATIONS FOR THE BUILDING OF YACHTS OF FIBREGLASS REINFORCED PLASTIC

The purpose of these regulations is to ensure that yachts constructed of fibreglass reinforced plastic shall have at least the same strength, weight and weight distribution as an equivalent yacht built in accordance with the Skerry Cruiser Regulation for wooden yachts.

The regulations of strength, weight and weight distribution are applicable also for building in materials other than fibreglass reinforced plastic.

4.1 PROCEDURE FOR CLASSIFICATION

An application shall be submitted to the Classification Board. The following drawings and specifications shall be submitted in triplicate, two copies of which will be returned with the board approval or comments:

Longitudinal and transverse sections showing the longitudinal and transverse structures of the yacht. These drawings shall show all transitions between load-bearing parts of the yacht, between the deck and the hull, between bulk-heads and the hull, as well as the mast mounting and rig fittings. These drawings shall also show the positions of horizontal planes 0 and 1, as well as the main section.

A description of the laminations and descriptions of reinforced parts of the hull, the deck and in the superstructure, etc.

A rig drawing showing the dimensions of mast and rigging, and the sail plan. All necessary dimensions shall be shown.

A calculation of displacement that confirms that the yacht satisfies the displacement requirements. In order to check the weight distribution the weight of each main part of the yacht, hull, deck, basic fitting-out and ballast keel, shall be shown.

After examination of the submitted drawings and specifications, the Classifying Board will confirm to what extent the structural design, materials, material dimensions, furnishings and equipment, comply with the Skerry Cruiser Rule.

4.2 CONSTRUCTION UNDER SURVEY

If a yacht shall be approved, it shall be surveyed by the Board, in order that:

The manufacturing conditions whilst under construction are in accordance with good practice.

Materials and components satisfy the provisions of the Rule.

That the individual constructional parts are designed and dimensioned accordance with the Rule and the approved drawings and specifications.

Construction and all work is carried out to the approval of the inspector and is in accordance with the Rule and good practice.

Arrangements and equipment satisfy the Rule provisions.

A full report on the inspections has to be prepared.

When the Board has confirmed that the yacht satisfies the prerequisites for approval expressed in these regulations, the Board will announce its approval.

The builder shall allow the Classifying Board's Inspector to have any access to the manufacturing and storage premises to be used during construction, and assist the Inspector during the examinations. The builder shall as far as possible impart complete and correct information of circumstances of importance for the investigation. The builder or his representative shall provide adequate assistance during testing and shall prepare the entire test. The builder is liable to pay the costs of all tests and examinations.

The building of a new yacht has to be surveyed:

- 1 When the templates are in position, but before the core material is applied or when moulds are in position.
- 2 When the hull and deck are laminated, but before they are joined together and frames and floors are fitted. The hull and deck shall each be weighed separately.
- 3 When the yacht is complete but before launching.

If necessary a final examination may be carried out after the yacht has been launched and rigged.

4.3 MATERIALS, PREMISES AND GENERAL WORKMANSHIP.

4.3.1 Manufacturing standards

Manufacturing premises shall be equipped and arranged according to the specifications of the material supplier for dealing with the material, to ensure the laminating process and the curing process can be met.

In premises used for laminating, the temperature shall never be below 18 degrees Centigrade and shall not vary more than plus or minus 3 degree Centigrade in the course of 24 hours. The temperature specified shall be maintainable irrespective of the outdoor temperature and shall be reached at least 25 hours before the laminating work has begun.

The relative air humidity shall be constant so that condensation is avoided, and shall not exceed 80 %. If laminating is carried out on the premises by means of spraying, the relative air humidity shall not be lower than 40 %. The specified humidity shall be maintainable irrespective of the temperature and the humidity outdoors.

Draughts through doors, windows, etc. and direct sunlight shall not occur in places where laminating works or curing process takes place.

Manufacturing premises shall be kept clean and free from dust, to keep raw materials and moulds unpolluted.

The ventilation system of the premises shall be so arranged so that the curing of the laminate is not impeded.

The storage premises shall be equipped and arranged so that the specifications of the material supplier relating to storage and treatment of the raw materials will be satisfied.

Storage premises for fibreglass shall be kept clean and as far as possible free from dust, so that the raw material will not be polluted.

The fibreglass shall, if the supplier does not recommend anything else, be stored in storage premises for at least 48 hours before it is transferred to the laminating premises, with a lower humidity than in the manufacturing premises, and at a temperature at least 2 degrees Centigrade higher than the temperature in the manufacturing premises. When such storage of the fibreglass material is not possible, it shall be stored for at least 48 hours in premises with the same environment as in the manufacturing premises.

The builder shall file certificates for polyester, gelcoat, topcoat and reinforcing material, so that the Classifying Board Inspector may satisfy himself that the raw materials satisfy the specifications.

The material in the load-bearing areas of the yacht shall be approved by the Swedish Administration of Shipping and Navigation.

4.3.2 Execution of the work

Gelcoat shall be applied in a thickness of 0.3 – 0.5 mm and may be sprayed. Runs in the gelcoat layer shall not occur. The gelcoat shall not cure for more than 24 hours before the laminating begins.

In general load-bearing parts shall be of hand-layered laminate. Other forming methods may be approved after extensive tests.

Laminating important hull parts shall be carried out by a trained staff or under supervision of a foreman who is experienced in assessing the execution of the work and the quality of the finished laminate.

Large structural parts shall be properly supported when they are removed from the moulds.

Permanent laminating of stiffening parts, furnishing etc. shall as far as possible be carried out on wet laminate. Laminate which has cured for more than 24 hours shall be free of wax, polished so that the fibres are uncovered, and cleaned, before parts which will be stressed are permanently laminated.

Laminate, the inside of which may be exposed to water, shall have a suitable outer coating (e.g. topcoat) which will protect the laminate. Stiffening parts and fittings which are fixed to this laminate shall also be given such a coating. When the edge of a laminate is not protected in some other way, it shall be covered with polyester which should be reinforced with at least one layer of matting.

When the edge of a sandwich panel is not protected in some other way, it has to be laminated.

After completion of lamination, the laminate shall cure for at least 24 hours under the same conditions as quoted for the manufacturing premises. If not possible, a specifically approved system for after curing shall be used.

4.3.3 Hand-layering

The fibreglass reinforcement shall be laid in the approved sequence. A layer of light matting of surface textile shall be laid against the gelcoat.

Only one layer of reinforcing material should be laid at a time.

Polyester shall be applied between each layer.

When splicing the reinforcing materials, the overlap shall be at least 50 mm. Gas and air inclusions shall be worked out of the laminate before the next layer is laid on. The rolling out of each layer shall be carried out carefully, and care shall be taken at transitions and corners.

The time interval between the laying of reinforced layers shall be within the limits prescribed by the raw material manufacturer. When manufacturing a thick laminate it shall be ensured that the time interval is not so short that heat exchange takes place.

4.3.4 Detail design

Structures in fibreglass reinforced polyester should be designed without sharp edges. Where sharp edges cannot be avoided, these shall be reinforced by means of an insertion or over-laminating with further laminate. The design should not be too complicated, and structures which impede inspection and repair shall be avoided. Structures which produce tension stressing at right-angles to the plane of the laminate shall be avoided, where such stresses can lead to delamination.

Stiffening parts, fittings etc. that are permanently laminated to side and bottom laminate shall be fixed with at least 2 mm laminate.

Thickness transitions in laminate shall be even and extend for at least 20 times the thickness difference, and for highly stressed laminate at least 40 times the thickness difference.

With sandwich structures, sudden changes in thickness shall not occur within the same laminate panel or in between sandwich laminate and single laminate.

Stressed transitions between sandwich structure and single laminate shall have a thickness transition extending at least twice the core thickness. Air inclusions at the edges of the core shall be avoided. Where it is a risk of moisture penetration, the edge of the core shall be filled.

4.3.5 Joints

Joints shall be simple and easy to check, and shall be designed so that no risk of delamination occurs in the jointed laminates.

4.3.6 Riveted and screwed joints

Rivets, screws and washers shall be of non-corroding material, or corrosion-protected.

Holes for rivets and screws shall be drilled and have the same diameter as the rivet or the screw. The distance from the hole centre to laminate edge shall be at least 2.5 times the hole diameter for rivets and 3 times the hole diameter for screws. The spacing of rivets be at least 2.5 times the hole diameter, and at least 3 times the hole diameter for screws. Rivet and screw spacing shall not exceed 150 mm.

Screwhead and nut shall have a washer with an external diameter of at least twice the hole diameter and a thickness of at least 0.1 times the hole diameter, but never less than 0.5 mm. No washer is required for a screwhead which satisfies the width requirement. The Classifying Board can demand larger washers in highly stressed joints.

In watertight joints, the rivet/screw shall be provided with sealing material before assembly and locked after assembly.

4.4 DIMENSIONS OF REINFORCED PLASTIC YACHTS

4.4.1 General

The following figures are designed for a sandwich laminate with a glass content of 30 per cent by weight, and a distance material with a density of 80 kg/m^3 . In cases differing from this ruling, calculations shall be shown and approved together with other drawings and specifications, before construction work has started.

If the glass content should exceed 30 % at the construction, the structure part shall also contain the calculated weight. When additional lamination material is added, this material shall be spread even over the surface of the part.

Topcoat and gelcoat shall not be included in the weight of the laminate.

4.4.2 Requirements for the finished laminate

Finished *uncured* laminate shall fill at least the following demands of mechanical properties:

Ultimate flexural strength	120 Mpa	(1 200 kp/cm ²)
Modulus of elasticity, tension	7 000 MPa	(70 000 kp/cm ²)
Ultimate tensile strength	90 MPa	(900 kp/cm ²)
Modulus of elasticity, bending	7 000 MPa	(70 000 kp/cm ²)

Ultimate tensile strength and modulus of elasticity, tension is determined in accordance with ISO/R 527-1966.

Ultimate flexural strength and Modulus of elasticity, bending is determined in accordance with ISO 178-1972.

The glass content of cured laminate shall be at least 27 and at most 40 per cent by weight, measured in accordance with ISO/R 1172-1970. The glass content of the laminate should not vary more than 4 per cent by weight.

The external laminate shall be at most 60 % and at least 50 % of the total lamination in a sandwich structure.

4.4.3 Laminate tests

When laminate tests are found to be necessary, this testing shall be carried out by an institution approved by the Classifying Board.

4.4.4 Keel strake / Keel sole

The keel stake shall be constructed as a single lamination with a weight/m² and width in accordance with Table VII. The keel strake shall have a regular curvature.

The keel sole shall be constructed as a single lamination with a minimum of weight/m² in accordance with Table VII.

4.4.5 Floors

Floors shall be fitted from a section $L_x/10$ forward of the mast, to a section aft of the rudder stock. Arm length, spacing, width, height and weight per m² in accordance with Table VII.

One extra floor shall be positioned close forward of the passing of the rudder stock through the hull.

Another floor shall be positioned at the forward end of the keel.

Extra floors shall be fitted under the mast partner (*mast foot*) with a spacing of half the table value along the whole mast partner.

When the mast partner extends over the forward end of the keel the extra floor above is cancelled.

When a transverse frame according to 4.4.6 is fitted between the ordinary floors, its lower part shall be designed as a floor.

When a floor is partly built at the sandwich laminate, it shall be extra reinforced under the floor.

The internal laminate shall here be reinforced with a weight per area corresponding to the whole external laminate. The width of the reinforcement shall be three times the width of the floor.

4.4.6 Transverse strengthening

4.4.6.1 Transverse strengthening may consist of bulkheads or frames with minimum dimensions and numbers according to Table VII. (Figure 11)

4.4.6.2 Transverse strengthening shall be placed at the forestay, the chain-plates, forward and aft end of the cabin and at the aft end of the cockpit.

The transverse strengthening at the chain-plates and at the forward end of the cabin may be the same.

4.4.6.3 The distance between mutual frames should not exceed 3m.

4.4.6.4 When a bulkhead or a frame is made of plywood or timber or other water-absorbent material, they shall be fastened to the hull according to Figure 11. The screw dimension according to Table VI "Rivets through vertical knees", spacing 100 mm, application according to 4.3.6.

4.4.7 Bilge lamination

4.4.7.1 The minimum curvature radius for a sandwich laminate is given by the formula:
$$R_{\min} = \frac{W \times \sigma_L}{\sigma_T \times (d + t)}$$

- R_{\min} the minimum curvature radius (mm)
 σ_T the compressive strength of the spacing material
 σ_L ultimate flexural strength of the laminate
 W bending resistance according to the table (cm³/m)
 d spacing material thickness (mm)
 t half the total laminate thickness (mm)

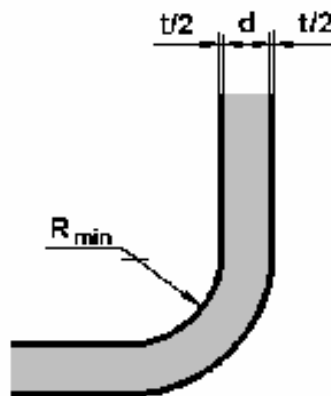

Figure 8 (Bilge laminate curvature)

4.4.7.2 When the radius of curvature for a single laminate bilge is less than 40 times the laminate thickness, the bilge shall be additionally reinforced.

4.4.8 Deck flanges

The joint between the deck and the hull shall, besides the planking and the deck, contain a weight per metre according to Table VII. The overlap between deck and hull flange shall be at least six times the thickness of the single laminate. The weight of the gunwale-moulding (*rail*) may after approval by the Classifying Board, be included in the weight.

4.4.9 Hull, deck and superstructure

4.4.9.1 The hull, deck and superstructure are constructed mainly as a sandwich laminate, and the superstructure shall be dimensioned like the deck. All dimensions to be in accordance with Table VII.

4.4.9.2 Deck openings shall be edge-reinforced to 25 per cent of the weight of the laminate. The reinforcement shall be at least 100 mm in width.

4.4.9.3 Openings larger than 750 mm shall be reinforced with a beam or similar, with a strength equating to the cut-out section.

4.4.10 Mast support

The hull shall be reinforced to withstand the forces transmitted from the mast to the hull. The loading at the mast foot shall be considered not less than 2 times the displacement.

The mast shall preferably be located on a mast foot placed above the floors. The mast foot shall have a length of 10 – 15 per cent of L_x

When the mast is deck-stepped the mast base shall be supported by a structure calculated for a compressive force of 2 times the displacement.

4.4.11 Fittings

Where fittings are to be installed, the hull and deck shall be reinforced so that an adequate loading distribution is obtained.

When designing these reinforcements, the magnitude and direction of the loading shall be taken into consideration. Fittings exposed to larger stress, as cleats, fairleads and alike shall be fitted at a single laminate.

The reinforcement shall cover an adequately large area around the fitting, and the individual layers shall be given a sufficient overlap.

Fittings shall be mounted with through-bolts.

4.4.12 Ballast keel

The ballast keel shall be fixed to the hull with bolts made of austenitic stainless steel containing molybdenum or of some other material resistant to seawater, depending upon the keel material. The number and dimensions of the bolts are according to 3.3.5.5 in the regulations for wooden yachts.

Internally under the nuts a solid plate of adequate material or possibly washers shall be placed.

4.4.13 Too small weight of the hull

When the weighing proves that the hull does not reach the minimum weight, the missing weight consisting of for example lead weights, shall be laminated to the hull at the ends of L_x . The weight distribution between the forward and aft end is free.

4.4.14 Too small weight of the deck

When the weighing proves that the hull does not reach the minimum weight, the missing weight, consisting of for example lead weights, should be laminated to the deck at the ends of L_x . The weight distribution between the forward and aft end is free.

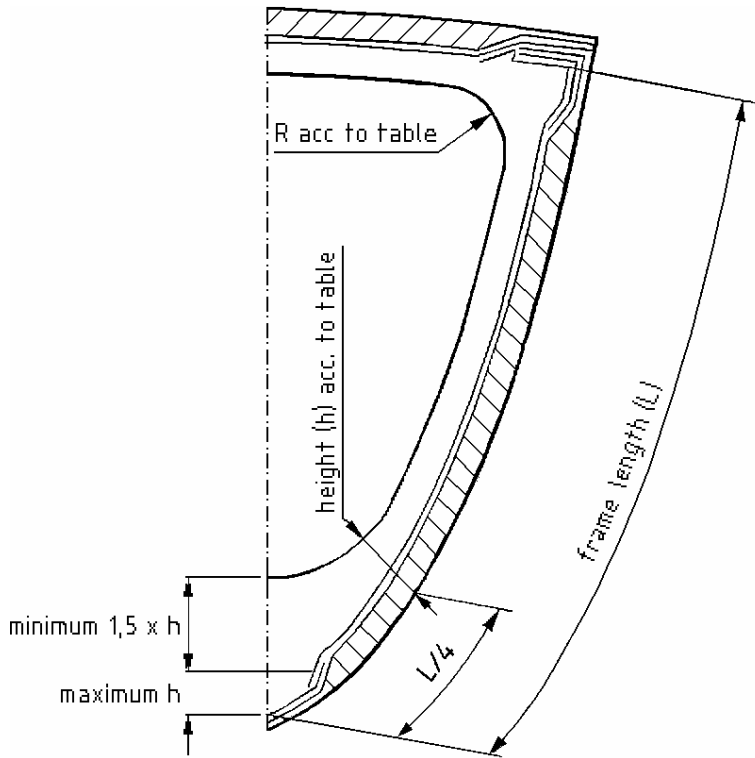

Figure 8 (Floor in the fore body)

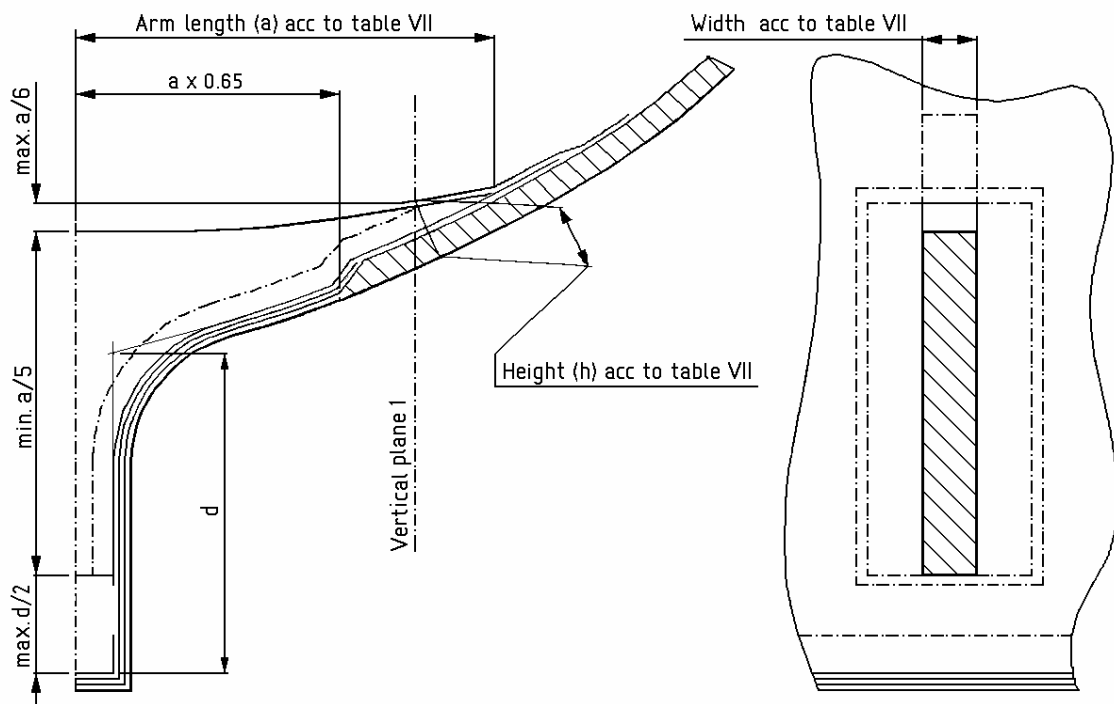

Figure 10 (Floor at the keel)

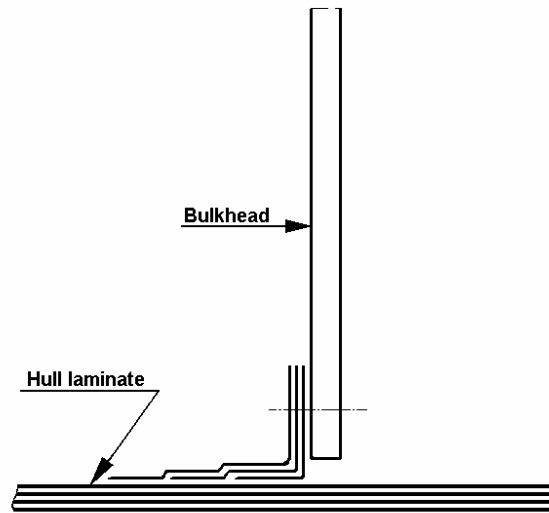
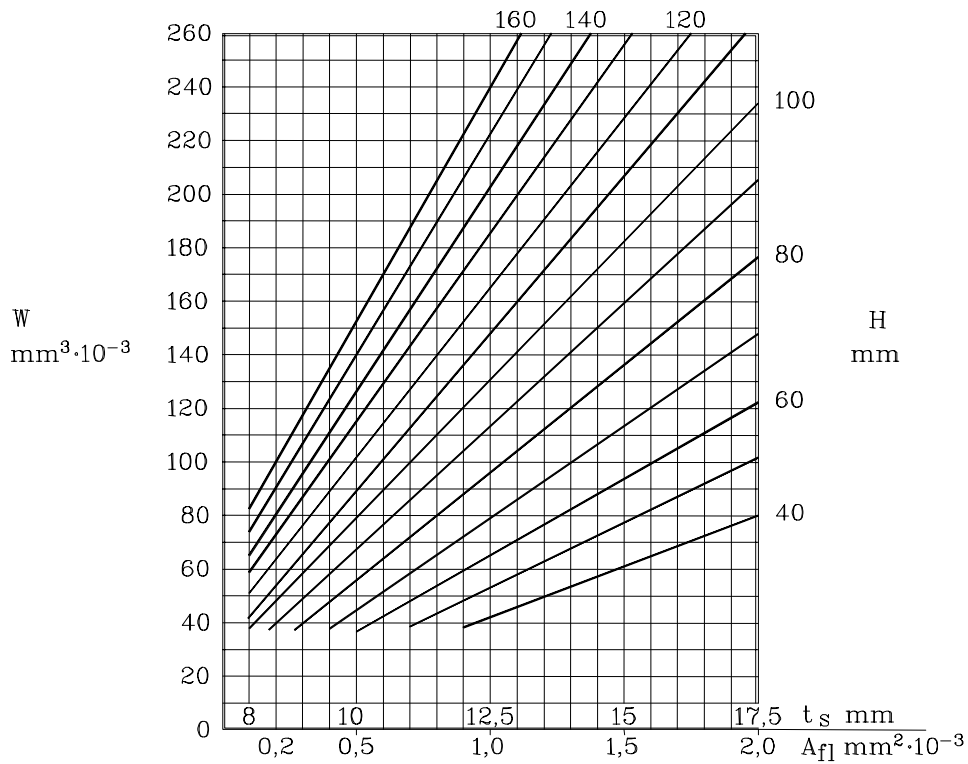
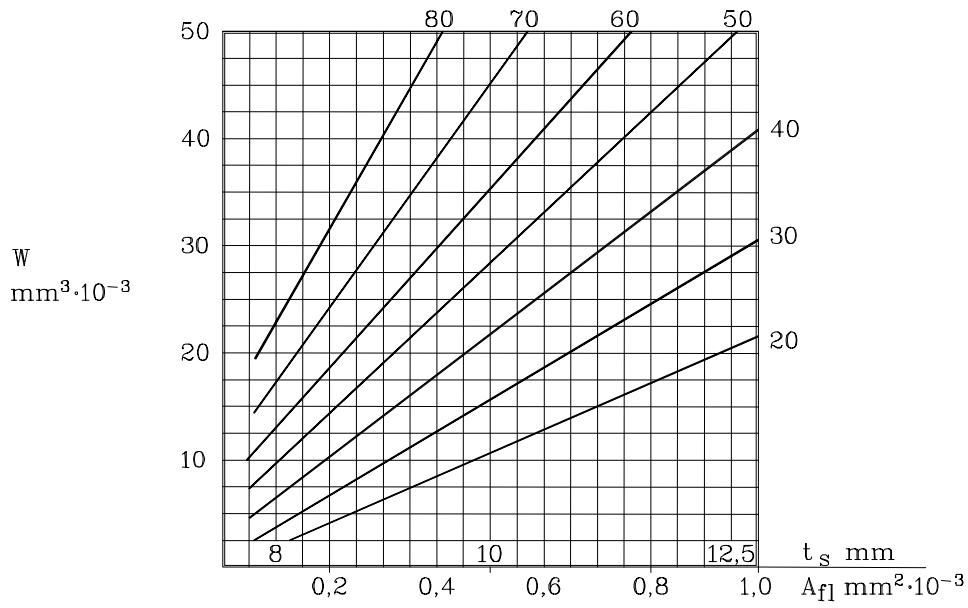
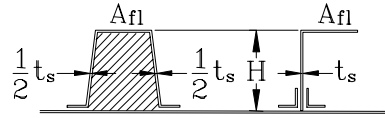

Figure 11 (Joining a bulkhead into the hull)

4.5 Table VII. DIMENSIONS, WEIGHTS AND FLEXURAL RESISTANCE

			Class m ²									
			15	22	30	40	55	75	95	120	150	
<i>Hull</i>												
panel weight inside 2/3 L _x	at least	kg/m ²	9.5	10.7	12.4	14.3	17.0	20.3	22.2	25.8	28.6	
panel weight outside 2/3 L _x	at least	kg/m ²	9.5	10.5	11.8	13.6	15.7	17.8	21.2	23.7	27.2	
flexural resistance	at least	cm ³ /m	10.6	14.3	18.4	22.9	29.6	38.3	47.3	57.6	69.5	
<i>Keel strake</i>												
panel weight	at least	kg/m ²	17.1	19.3	22.3	25.7	30.6	36.5	40.0	46.4	51.5	
(thickness of laminate (t))		mm	(11.4)	(12.8)	(14.9)	(17.2)	(20.4)	(24.4)	(26.6)	(31.0)	(34.3)	
width (b/2) of stem at the deck	at least	mm	65	75	90	100	110	125	135	150	165	
stem at forward end of L ₀	at least	mm	95	110	125	140	150	165	185	200	220	
stem at the mast	at least	mm	135	155	180	215	250	285	305	325	370	
horn timber at the sternpost	at least	mm	90	110	135	170	205	235	255	275	300	
horn timber at aft end of L ₀	at least	mm	65	80	90	100	110	125	140	155	170	
horn timber at the transom	at least	mm	50	60	70	80	90	100	110	125	140	
<i>Keel sole</i>												
panel weight	at least	kg/m ²	30.0	42.8	49.5	57.2	68.0	81.2	88.8	103.0	114.0	
(thickness of laminate (t))		mm	(25.0)	(28.5)	(33.0)	(38.1)	(45.3)	(54.0)	(59.2)	(69.0)	(76.0)	
<i>Floors</i>												
spacing	at most	mm	500	500	500	500	500	500	500	500	500	
arm length (a)	at least	mm	250	280	320	350	390	440	480	510	550	
height in vertical plane 1 (h)	at least	mm	51	58	67	77	88	100	112	126	140	
width	at least	mm	35	40	47	54	62	70	78	88	98	
panel weight	at least	kg/m ²	9.5	10.7	12.4	14.3	17.0	20.3	22.2	25.8	28.6	
(thickness of laminate (t))		mm	(6.3)	(7.1)	(8.3)	(9.5)	(11.3)	(13.5)	(14.8)	(17.2)	(19.1)	
<i>Transverse frames</i>												
number	at least		4	4	4	5	5	5	6	6	6	
bulk head, thickness	at least	mm	12	12	12	13	13	14	14	15	15	
frames, flexural resistance	at least	cm ³	10.8	15.0	20.2	26.4	37.0	53.5	78.0	115.0	170	
min internal radius of curvature	at least	mm	125	140	155	170	190	220	250	285	330	
<i>Deck</i>												
panel weight, beam > 0,5 × b _m	at least	kg/m ²	8.7	9.8	11.1	12.5	14.0	15.6	17.9	20.6	23.6	
beam ≤ 0.5 × b _m	at least	kg/m ²	8.7	9.7	10.8	12.2	13.5	15.0	17.2	19.9	22.6	
flexural resistance, beam > 0.5 × b _m	at least	cm ³ /m	33.3	38.9	45.0	51.0	59.5	69.7	78.5	88.4	99.8	
beam ≤ 0.5 × b _m	at least	cm ³ /m	33.3	33.3	38.9	45.0	51.0	59.5	69.7	78.5	88.4	
<i>Hull / Deck flange reinforcement</i>												
Weight	at least	kg/m	0.6	0.9	1.2	1.6	2.1	2.9	3.7	4.7	5.8	

The thickness of laminates (t) above are approximations, when the thickness varies with the content of glass. In all calculations and classifications weight shall decide the limit.



Resistance to bending, calculated contribution from main laminate, for sections as a function of flange area A_{fl} , core height H step thickness t_s .

Diagram 1 (Bending resistance for frames)

5 MAST AND RIG

5.1 GENERAL

5.1.1 Only 55-150sqm

The mast diameters specified in the table apply to masts where the sail measuring height H is fully utilised. For a lower figure of H, a reduction in the mast diameter of 1 mm for each 100 mm below the table value of H.

5.1.2 When the type of rigging is uncommon, the Classifying Board decides with regard to the regulations the dimensions of the mast.

5.1.3 A mast with a section other than circular, shall nevertheless at least have the specified table value in the athwartships direction.

If the mast has a substantial permanent bend between the deck and the lower shroud fasteners, the mast shall be reinforced in an adequate way.

5.1.4 The sail measuring height H (Figure 19) is measured from the lower edge of the top measurement band to topside of the covering board at the mast after side, in the following:

value a: from a point at the aft side of the mast at the level of the lower edge of the top measurement band, along a straight line to the top side of the deck (or to the top side of the cabin at the mast after side);

value b: the beam camber at the after side of the mast, i.e. the height of from the topside of the deck (or the topside of the cabin) amidships to the topside of the covering board, both measured in a section at the mast aft side. The two values a and b added gives the value H.

When the top measurement band is missing, the centre of sheave hole is used.

5.1.5 Maximum height of the upper side of the main boom over the covering board (HB) is measured in the same way (Figure 19), thus:

value c: from the top edge of the lower measurement band along the after side of the mast to the top side of deck,

value b: beam camber at the after side of the mast, see 5.1.4.

The two added values gives the measurement HB.

The height of the lower measurement band over the covering board shall not exceed the value HB from Table VIII.

5.1.6 For gaff-rigged yachts, the sail measuring height is calculated as the sum of following 3 values:

Maximum height of the main boom over the cover board (HB) + length of the mainsail along the mast (value M) + length of the gaff (value G) (according to the measuring instructions)

5.1.7 Only 55-150sqm

When the mast has a larger section, then the area aft of the specified mast diameter shall be included in the sail area.

5.1.8 The lower shrouds on each side running to the lower mast without spreaders, shall have a breaking strength equal to at least the displacement of the yacht.

The top shrouds on each side shall have a breaking strength equal to at least 70 % of the displacement.

5.1.9 Fittings of the shrouds and stays shall have a strength equal to the calculated strength for each shroud or stay. Other spars and rigging shall have a strength corresponding to the mast.

5.1.10 Outriggers of any kind as sheeting point for sails are prohibited. The fitting point of the forestay and foresail tack shall be close to the midship line.

Arrangement for transverse shifting of the foresail tack is prohibited.

At the foresail may no device, besides the spinnaker pole, be placed which has the possibility to spread the foresail beyond the front edge of the fore triangle. (i.e. the straight line between upper point of I and foremost point of J).

When the spinnaker pole is used, one end shall be set to the mast.

It is not permitted to at the same time carry more than one spinnaker pole.

No device except the spinnaker pole is allowed to spread the spinnaker.

5.1.11 Rotating masts at 55-150sqm

Rotating masts shall be separately examined by the Classifying Board.

Rotating masts in other materials than wood shall have a minimum panel weight stated in Table IX:

The area is to be measured at the outside of the mast. The area in the midship plane which exceeds the area for a normal mast is added into the sail area according to Figure 20.

5.2 WOODEN MAST FOR 55-150 sqm CLASSES

5.2.1 The mast diameters, specified in Table VII, shall be held at 1/3 of the sail measuring height H (compare 5.1.4) above the deck, and may be reduced to 95 % at the deck, to 85 % at 2/3 of the height of the mast above the deck and to 50 % at top of the sail measuring height H. The transitions between the specified diameters shall take place in an even curve.

5.2.2 The reduction upwards and downwards from the largest diameter shall take place in an even curve. The material thickness in every section of a hollow mast shall be examined by the Classifying Board. (A guide value of the minimum thickness is 1/5 of the mast diameter in the same section.)

5.2.3 Approved materials for wooden masts with dimensions given in Table VIII are pine, Oregon pine, spruce and fir. Other materials may be used after the approval of the Classifying Board.

5.3 ALUMINIUM MAST FOR 55-150 sqm CLASSES

5.3.1 The mast shall be extruded of aluminium with dimensions given in Table VIII, i.e. the initial material shall have the same cross-section along the whole of its length. The mast may be tapered in an even curve from the top of I to the top of the mast.

5.3.2 The diameter at the top shall be at least 50 % the mast diameter (table value).

5.4 OTHER MATERIAL MASTS FOR 55-150 sqm CLASSES

5.4.1 Requirement of weight and centre of gravity.

The principals of another material mast is based on that the mast shall have the same diameter, weight and centre of gravity as a wooden mast consisting of wood of a density of 450 kg/m³.

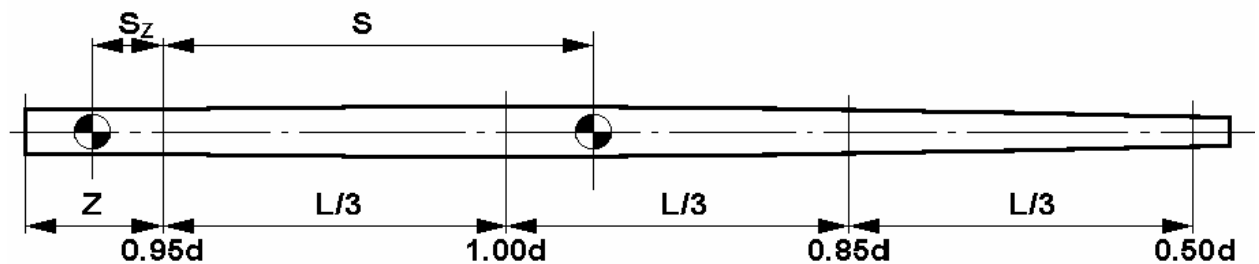

Figure 12 (Measurements: other material masts)

5.4.2 Deck stepped mast

The location of the centre of gravity from the butt end (S)

L is the height of the mast above the deck.

S (centre of gravity above the deck) shall be at least $0,435 \times L$.

The mass (m)

m shall be larger than $177,6 \times d_i^2 \times L$ (d_i is the table value of a hollow wooden mast).

or

m shall be larger than $277,5 \times d_m^2 \times L$ (d_m is the table value of a solid wooden mast).

L and d are given in meter and m in kg.

5.4.3 Keel stepped mast

s and m shall be the same as for a mast on deck (5.4.2).

The mass of the mast section under the deck (m_z)

m_z shall be larger than $75,5 \times d_i^2 \times Z \times (1 + a + a^2)$ (hollow mast)

or

m_z shall be larger than $117,8 \times d_m^2 \times Z \times (1 + a + a^2)$ (solid mast)

The location of centre of gravity of the mast section under the deck S_z

$$S_z = \frac{Z \times (1 + 2 \times a + 3 \times a^2)}{4 \times (1 + a + a^2)}$$

Z is the length in metres of the mast section under deck and a is the diameter of the mast at the butt divided by the diameter at the deck.

The mass of the mast shall be at least: $m_{\text{korr}} = m_z + m$

The centre of gravity of the mast shall be at least over the butt:

$$S_{\text{korr}} = \frac{m \times s - m_z \times s_z}{m_{\text{korr}}}$$

5.5 MASTS OF THE 55-150 m² CLASSES

5.5.1 Wooden mast

The athwart ships measurement of a wooden mast of the 55-150 m² classes may be reduced 20%.

To allow the reducing are calculations of acceptable strength of the transverse rigging required.

5.5.2 Aluminium mast

Aluminium masts shall keep the measurements given in table VIII. Calculations of acceptable strength of the transverse rigging are required.

5.5.3 Other material masts

Table VIII and 5.4.2 and 5.4.3 are valid then calculating other material mast of this classes. A reduction of the weight and the diameter may be done according following. The centre off gravity shall be kept.

When the weight and the centre of gravity have been calculated according to hollow mast (d_m) may following reducing be done

The width of the mast may be reduced to $2/3$ of d_m .

The weight of the mast may be reduced 20%

To allow the reducing of the weight and the section length and width of the mast, calculations of acceptable strength are required.

5.6 MASTS OF THE 15-40 m² CLASSES

5.6.1 Front area (A)

Measured by the formula $A = (D_0 + 4 D_1 + 2 D_2 + 4 D_3 + D_4) * H / 12$

M = Measurement of mainsail hoist according to 6.6.1.1

H = The height of sail plan according to 5.1.4

D0 is the width at the boom

D1 is the width at $1/4$ H

D2 is the width at $1/2$ H

D3 is the width at $3/4$ H

D4 is the width at H

5.6.2 Mast top weight (MTV)

Is weighted at the top measure band when the mast is balanced at the boom mark. The lower part of rigging and halyards hanging over the support. All rigging in sailing position according to ISAF's regulations.

Fittings below the boom mark may be removed during weighting.

Minimum MTV is calculated by the formula: $MTV = k * (M^2 - R^2) / 2M$

M = Measurement of mainsail hoist according to 6.6.1.1

R = Root length (length from the top edge of the boom mark to the lower edge of the mast)

K = Constant (according to table VIII)

5.6.3 Regulations to avoid undesirable designs

The long ship measurement of the mast in any section must not be less than the width.

The diameter of the mast shall be continuous and be decreasing or constant towards the ends.

5.6.4 Reduction for lower sail measuring height.

H = sail plan height according to 5.1.4

A = front area according to 5.6.1

A may be reduced to A_x then the sail measuring height H_x is lower than max H according to table VIII

$$A_x = A * (H_x/H)^2$$

5.6.5 Rotating mast

A rotating mast receives a supplementary area according to following:

A_t = The athwart ship area of the mast

A_l = The long ship area of the mast

M = Main sail hoist according to 6.6.1.1

The athwart ship area is calculated as following:

$$A_T = (B_0 + 4 B_1 + 2 B_2 + B_3 + B_4) * M / 12$$

B_0 is the width taken at the boom

B_1 is the width taken at $1/4 M$

B_2 is the width taken at $1/2 M$

B_3 is the width taken at $3/4 M$

B_4 is the width taken at H_{max}

The long ship area is calculated as following:

$$A_l = (L_0 + 4 L_1 + 2 L_2 + 4 L_3 + L_4) * M / 12$$

L_0 is the length taken at the boom

L_1 is the length taken at $1/4 M$

L_2 is the length taken at $1/2 M$

L_3 is the length taken at $3/4 M$

L_4 is the length taken at H_{max}

Supplementary area of a rotating mast = $A_l - A_t$

A_l / A_t shall be 1,5 – 2

5.6.6 Uncommon designs

The Classifying Board may require calculations of the strength when the Board find it motivated.

5.7 Table VIII Mast

Sail area (S)	at most	m ²	Class sqm.								
			15	22	30	40	55	75	95	120	150
Sail measuring height (H)	at most	m	9.65	11.15	12.50	14.20	16.40	18.80	20.80	23.10	25.50
Height of the main boom (HB) (see Figure 20)	at most	m	1.00	1.03	1.07	1.11	1.16	1.21	1.26	1.32	1.38
Height of the foretriangle(I)	at most	m	6.75	7.60	8.70	9.90	11.50	13.20	14.60	16.20	17.80
Panel weight, rotating mast	at least	kg/m ²					9.7	11.2	12.6	14.1	16.3
Front Area (A)	at least	m ²	0,875	1,109	1,352	1,672					
Constant of mast top weight (K)			2,58	3,56	4,69	6,10					
Wooden mast											
Diameter of the mast:											
solid mast (d_m) ¹⁾	at least	mm					158	184	208	233	260
hollow mast (d_i) ¹⁾	"	mm	119 ²⁾	129 ²⁾	139 ²⁾	155 ²⁾	182	212	239	268	300
Aluminium mast											
Diameter of the mast (d) ¹⁾	at least	mm					151	176	199	223	249
Weight:	at least	kg/m					5.85	7.94	10.14	12.73	15.85
Long ship moment of inertia (I)	at least	cm ⁴					650	1190	1925	3040	4775

¹⁾ In the 55-150m² Classes may the transverse measurement be reduced to 2/3 of (d)

²⁾ These figures are only be applicable with 6.7.5

6 MEASUREMENT INSTRUCTIONS

6.1 GENERAL REGULATIONS

6.1.1 Local inspectors and measurers

The governing body of a country's sailing association will appoint (in accordance with the proposal of a Classifying Board where such has been set up) in suitable locations, local inspectors and measurers who have to carry out necessary inspections and measurements within a specific district, that likewise laid down by the association.

An appointed local inspector who on behalf of the Classifying Board carries out prescribed inspections in respect of building and fitting-out checks (in accordance with the provisions of the building regulations as well as any special instructions from the Classifying Board) is simultaneously a natural choice as a measurer and is responsible for carrying out hull measurements as well as sail measurements and equipment checks as necessary.

A person appointed as a measurer shall carry out necessary hull and sail measurements as well as equipment checks.

Under special circumstances the sailing association may order a local inspector or measurer to perform official duties within a district other than that for which he has been appointed.

6.1.2 Restrictions

A local inspector or measurer is prohibited from inspection or measuring:

- 1) A yacht that he has designed or built, or where he has taken part in its building or rebuilding.
- 2) A yacht which was built by a firm in which he has a financial interest.
- 3) A yacht which he has ordered, owns or is part-owner in.

6.1.3 Prohibition against taking extra measurements

A local inspector or measurer may not take measurements other than those required by the regulations, except in cases in which the governing body of the sailing association or the Classifying Board does specifically orders him.

6.1.4 Measuring instruments

A steel tape shall be used when measuring.

All measurements shall be taken with the greatest possible care and shall be read at least twice.

Steel measuring tapes shall be of class II.

When weights are taken a scale approved by the Classifying Board shall be used.

6.1.5 Report of inspection or measurement

An inspection or measurement shall be recorded by the pertinent official who, after his official duties have been completed, will submit a report to the Classifying Board with the necessary details.

6.1.6 Official appeal

If a yacht's owner or his representative wishes to appeal against a specific inspection or measurement, an explanatory letter shall be submitted to the Classifying Board or the Swedish Sailing Federation. The board or the Swedish Sailing Federation will allow a new inspection or re-measurement to be carried out for a fee, such a new inspection or re-measurement will be decisive. Such a charge will however be waived if the appeal is found to be justified.

6.2 MEASURING OF THE HULL

6.2.1 Marks

Main section. The transverse section at maximum mean breadth.

6.2.1.1 The freeboard marks shall comprise of right-angled isosceles triangles, with each of the two equal length sides being at least 60 mm in length.

6.2.1.2 Trim marks and keel marks shall comprise of rectangles of at least 100 mm x 20 mm in size.

6.2.1.3 Marking nails, marking screws and band on wooden yachts.

Marking nails and marking screws shall have a somewhat bulged head, be easy to separate from other nails and screws in the planking and may not be plugged. The marking nails and marking screws need not be as large as other nails and screws.

6.2.1.4 Marking nails, marking screws and band on plastic yachts.

On yachts built in plastic, the marking nails below horizontal plane 1, as well as the nails marking the bow width B and the freeboard marks, may be indicated with drilled hollows in the gelcoat 4-8 mm in breadth and at least 3 mm in depth. On the freeboard these hollows may be filled with gelcoat in a different colour. Freeboard marks, keel marks and trimming marks on plastic yachts may be recessed to half of its thickness and be fixed by cement or by screws.

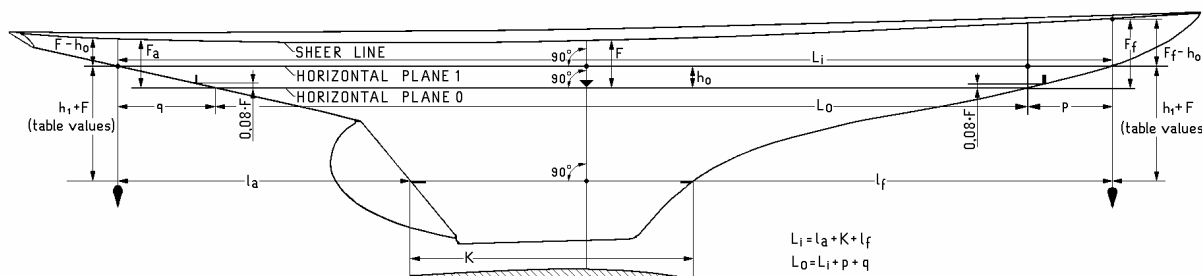

Figure 13 (Marks)

6.3 AFFIXING OF THE MARKS

The marks shall be affixed in accordance to the designer's instructions and shall be performed through the customer (or through the manufacturer) and at his expense.

The location of the marks in relation to the floating in fresh water shall be verified by the local supervisor or the surveyor (Figure 13).

6.3.1 The freeboard marks shall be affixed on the main section with the right angle pointing downwards so that the apex touches horizontal plane 0.

Marking nails and marking screws. The main section is marked on horizontal plane 1, the nails shall be visible inboard to facilitate the measurement of the breadth b_1 . A marking nail or screw shall also be affixed on the main section at a distance of $h_1 + F_1$ (table values) below horizontal plane 1.

The forward and aft ends of L_m and L_0 shall be marked with marking nails or marking screws, the bow measurement B shall also be marked at horizontal plane 1 on the frame section of the forward end of L_0 .³ On the frame sections at the forward and aft ends of L_m marking nails or marking screws shall also be affixed directly under the covering board.

6.3.2 The trim marks shall be affixed so that the longest outer edge is located in a transverse section, and passes through that point at which a horizontal plane at a distance of $0.08 \times F_1$ above horizontal plane 0 intersects the hull externally in the midship plane, fore and aft. The trim marks have only to be affixed on one of the sides of the yacht (starboard).

³By frame section concerns every vertical transverse section, parallel to the main section and with the right angle to the midship plane and to the horizontal plane. Main section or other frame section has not to be in the same place as a structural frame.

6.3.3 The keel marks shall be affixed so that the longest upper edge lies in a horizontal plane at a distance of $h_1 + F$ (table values) below horizontal plane 1. The keel marks have only to be affixed on one of the sides of the yacht (starboard).

The freeboard marks, trim marks and the keel marks shall at least be clearly visible, even then the yacht is coated.

6.4 DISPLACEMENT CONTROL

The customer or the designer shall according to the construction regulations submit to the Classifying Board a calculation of the displacement showing that the yacht satisfies the displacement requirements (form is available at the Classifying Board). At the same time the customer or the designer ought to present the body plan of the yacht and verify that the frame areas in the calculation of the displacement is correctly stated.

When the displacement is close to the prescribed minimum displacement (less than 4 %), certain frame areas shall be measured by the local supervisor to get a more precise control.

The total displacement of the complete yacht shall be confirmed by weighing.

6.5 CONTROL OF THE MEASUREMENTS

Measuring the hull of the yacht for the first time of as well as thereafter shall be done on shore. The measuring of the hull is most suitably done during the construction.

Checking the measurements of the hull of the yacht may, when it is found necessary, be done on the water.

Measuring on land: The control will be simplified if the yacht is arranged with the midship plane and the main section vertically (confirmed with a plummet), which often is normal during the construction. Then each measurement can be confirmed in the following way and order:

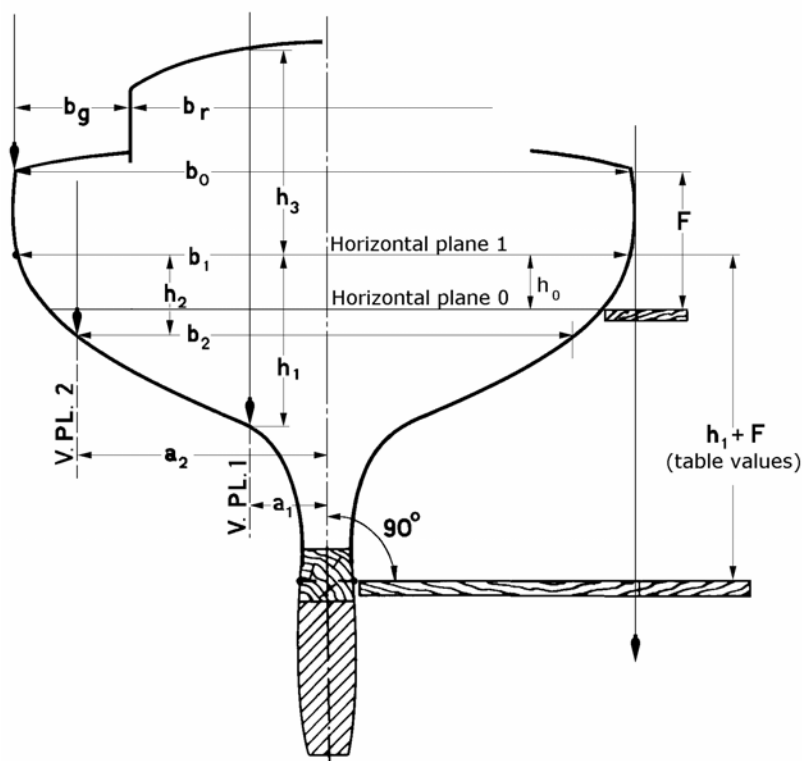

Figure 14 (Measurements at the main section)

6.5.1 MAXIMUM MEAN BREADTH (bm_x) is calculated according to the formula: $bm_x = \frac{b_0 + 4b_1 + b_2}{6}$, where

b_0 , b_1 and b_2 are measurements of the breadth on the inside of the main section (Figure 14):

b_0 immediately below the covering board, b_1 in horizontal plane 1 (situated at the distance of h_0 over horizontal plane 0), b_2 at the distance of h_2 (table value), below horizontal plane 1.

b_0 shall not be less than b_1 .

These measurements shall be taken, when the yacht is planked, the beam and clamps are mounted. One or more of the measurements can be taken externally, in these cases the thickness of the planking shall be deducted.

6.5.2 THE HEIGHTS (h_1 and h_2) FROM THE INSIDE OF THE HULL PLANKING TO HORIZONTAL PLANE 1 IN THE VERTICAL PLANES 1 AND 2 are suitably measured through stretching a cord between the marking nails at the main section in horizontal plane 1, then hold a plummet line at the distances a_1 respectively a_2 from the midpoint of the cord (in the midship plane), the measurements h_1 respectively h_2 are taken from the cord along the plummet line to the inside of the planking (Figure 14).

6.5.3 THE FREEBOARD (F) AT THE MAIN SECTION is confirmed by holding a scale vertically (along a plummet line) and touching the planking outside, then the measurement can be taken from a horizontal rule (for example a spirit level) touching the lower edge of the freeboard mark in horizontal plane 0 to the upper side of the covering board.

The measurements shall be taken on both starboard and port sides. At the same time the vertical distance between the lower edge of the freeboard mark and the marking nail in horizontal plane 1 is confirmed to correspond to the table value h_0 (Figure 14).

6.5.4 THE KEEL LENGTH (K). At the same time as the freeboard is confirmed, the vertical distance from horizontal plane 1 to the marking nail or marking screw is most suitably checked: it shall be equal to $h_1 + F$ (table values). The end of the horizontal rule is placed at the mentioned marking nail or marking screw, then the measurement can be read at the vertically held scale (Figure 14).

Then the distance below horizontal plane 1 to the upper edges of the keel marks is checked by holding the horizontal rule along the keel and parallel to the midship plane. At the same time the measurement K is taken. (Figures 13 and 14).

6.5.5 THE IDEAL LENGTH (L_x) is suitably measured by fixing plummet lines at marking nails or marking screws at the end of L_m and where the keel intersects a plane $h_1 + F_1$ below horizontal plane 1 i.e. at the end point of K. L_m is equal to $l_a + K_m + l_f$, there l_a is the horizontal distance from the after end point of K to the plummet line at the after end point of L_m , and l_f is the opposite distance from the fore end point of K to the plummet line at the fore end point of L_m .

The measurements l_a and l_f are on smaller yachts taken along a horizontal rule, on larger yachts along a horizontally stretched cord. That l_a and l_f intersections to the plummet lines at end point of l_m are at a distance below the latter points has to be carefully checked. The control of the ideal length shall be done at first when the yacht is planked and decked, and the head and after body shall be well supported. (Figure 13).

6.5.6 THE LENGTH IN HORIZONTAL PLANE 0 (L_0). That the marking nails or marking screws at the end points of L_0 are correctly situated is checked by holding a horizontal rule at the distance of h_0 below the end points of L_m . From the plummet lines at the end of L_m the measurements q and p are taken to marking nails or screws (Figures 13 and 15), their sum is deducted from L_m ($L_0 = L_m - q - p$)

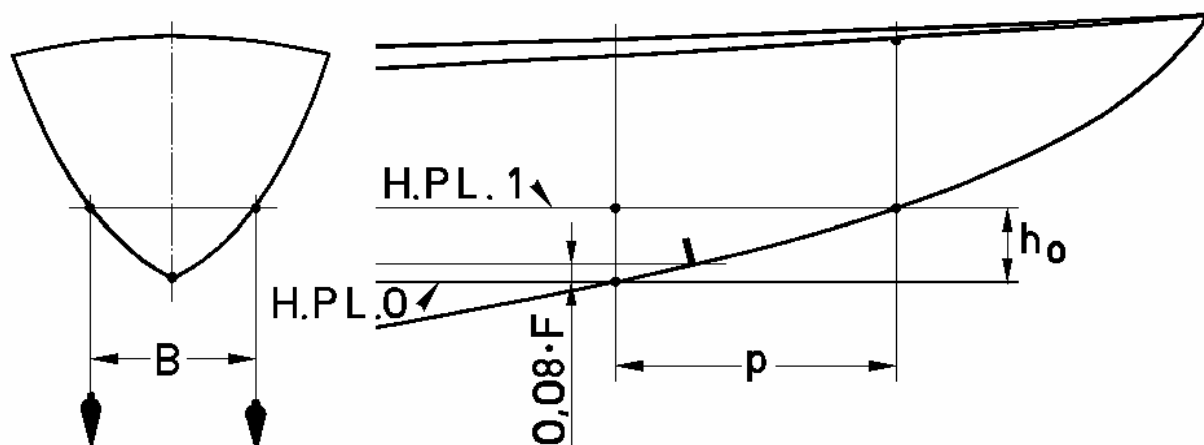

Figure 15(Measuring the bow width B)

6.5.7 THE BOW WIDTH (B), EXTERNALLY MEASURED, IN HORIZONTAL PLANE 1 ON A FRAME SECTION AT THE FORWARD END OF L_0 .

Plummet lines are fixed at the marking nails or marking screws at the B measurement, the measurement can easily be taken directly under the forward end of L_0 (Figure 15). At the same time the height of the marking nails or marking screws over the forward point of L_0 is checked.

6.5.8 THE REGULATIONS AT ITEM 1.3.4. The value of P/h_0 is calculated to confirm that item 1.3.4 of the rules is fulfilled. When P/h_0 at most is 5, B shall not be larger than $0.1 \times bm_m \left(\frac{p}{h_0} - 1 \right)$, when P/h_0 is greater than 5, B

shall at least be $0.4 \times bm_m$.

The regulation of item 1.3.4.2, that no point in any frame section may be situated lower than the section's external point of intersection with the midship plane, i.e. that no inward bend exists at the midship plane, is followed, is easy seen and can, if necessary, be checked through holding a horizontal rule under the stern post etc.

According to 1.3.4.3 no point below the horizontal plane 1 can be placed aft of the point where the horizontal plane 1 intersects the outside of the hull (L_x 's aft end). This is obvious when the plummet line at the aft end of L_x is fixed.

Regarding item 1.3.4.4 a local supervisor or a measurer, when he observes irregularities in the area where measurements are to be taken, and which risk the intention of the measurements, has to inform the Classifying Board, which have to order further instructions.

The fulfilling of item 1.3.4.5 is checked by a straight-edge or by a stretched cord.

6.5.9 THE TRIM MARKS. That these are correctly fixed at a distance of $0.08 \times F_i$ above horizontal plane 0, is checked by holding a horizontal rule at the ends of L_0 and the vertical distance from the outer edge of each mark in the midship plane is measured.

6.5.10 THE SHEER OF THE COVERING BOARD. That the covering board forms a continuous concave curve can often be checked by observing the yacht at some distance side-face. In doubtful cases a rule is held along the upper side of the covering board.

The freeboards aft and fore (F_a and F_f), counted from horizontal plane 0 to the upper side of the covering board, are calculated through measuring $F_a - h_0$ and $F_f - h_0$. This can be done with a plummet line and a horizontal rule at respective places. The horizontal rule is held athwartships at the aft and fore endpoints of L_x , and the measurement is taken along the plummet line to the upper edge of the covering board. F_a and F_f are calculated as well as $F_a + F_f - 2F_x$. The value $F_a + F_f - 2F_x$ shall not be less than that which is indicated in Table I.

6.5.11 DECK CAMBER. The regulation that the beams shall have curvature corresponding to at least a height 1/25 of the beam at the maximum breadth, is best confirmed through making a jig of pasteboard or wood, with the minimum curvature and then compare the beams with the jig.

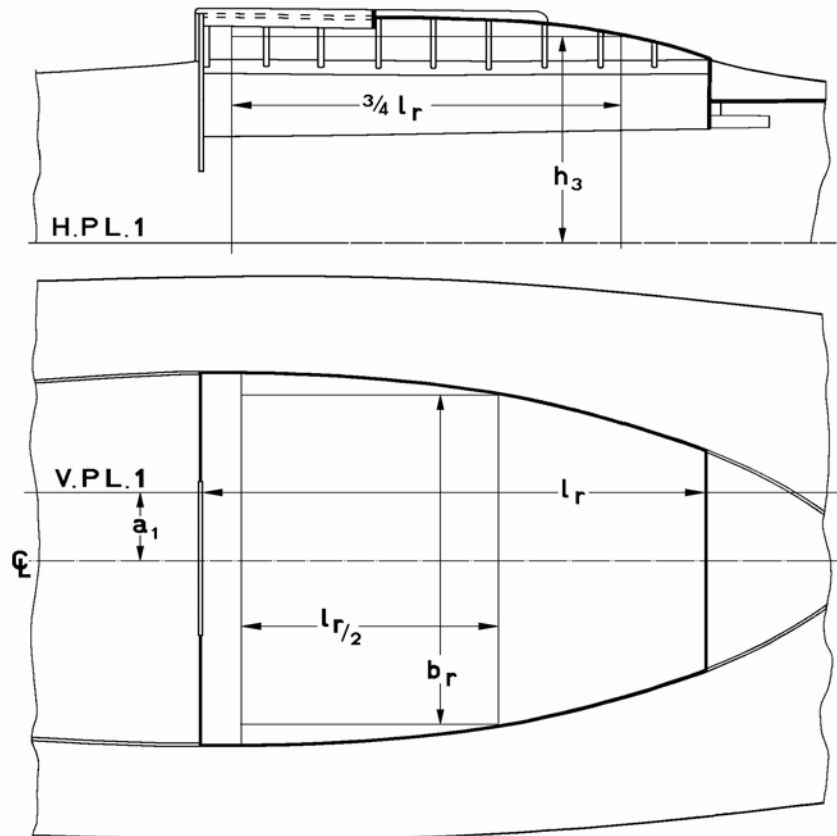

Figure 16 (Measurements of the cabin)

6.5.12 THE LENGTH OF THE CABIN (l_r) is measured inside in vertical plane 1. The measurement is taken horizontally at deck level and at a distance a_1 from the midship plane.

The measuring shall be made by directions given by supplemental drawings (according to 1.4.1) when attached.

6.5.13 THE WIDTH OF THE CABIN (b_r) is measured inside at deck level. The width within a length of $1/2 l_r$ (table value) shall nowhere be less than the value b_r in Table II.

The measuring shall be made by directions given by supplemental drawings (according to 1.4.1) when attached.

6.5.14 THE HEIGHT (h_3) TO THE UNDER SIDE OF THE CABIN OR DECK FROM HORIZONTAL PLANE 1 is measured inside in vertical plane 1. The height within a length of $3/4 l_r$ (table value) may not be less than value h_3 in Table II.

The control is most suitably made through first stretching a cord between the marking nails in horizontal plane 1 at the main section, from the midpoint of the cord set of a_1 and from that point parallel to the midship plane hold a horizontal rule or stretch a cord horizontally. The distance from the horizontal level to the cabin ceiling is measured along a plummet line (Figure 16).

6.5.15 THE GANGWAY WIDTH (b_g) is measured in the same direction as the beams, i.e. in a vertical plane right-angled to the midship plane, from the outer side of the cabin side or of the cockpit coaming to the outer side of the planking (Figure 14). The measuring can be done at the inside, in this case deductions shall be made for the thickness of the cabin side or the cockpit coaming and with compensation to the inclination.

6.5.16 OPEN COCKPIT AREA, WITHIN THE COAMING. Open cockpits where the cutting away from the deck is common, i.e. comparable to a parallel trapezoidal, the area is calculated according to the

formula $\frac{l_s}{6} \times (y_0 + 4 \times y_1 + y_2)$, where l_s is the distance between the parallel sides y_0 and y_2 , and y_1 is the width of the cut away at half of l_s .

6.5.17 THE HEIGHT OF THE COAMING, which means the value from Table II, is in a general shaped cockpit checked at least at half l_s . The height is measured from the top side of the deck.

6.6 RIG MEASUREMENTS

Sail measuring is performed by measuring lengths along the hull and spars, in the following way:

6.6.1 Triangle mainsail on a straight mast

Following measurements are to be taken:

The mainsail hoist M

The mainsail foot B

6.6.1.1 (M). Measurement of the mainsail hoist is taken from the lower edge of the top measurement band along the after side of the mast to the top edge of the lower measurement band. When the top measurement band is missing the measurement is taken to the centre point of the sheave of the main halyard.

The main sail halyard shall run over a sheave in the top of the mast, where the slot sets off not more than 10 mm behind the after edge of the mast. The headboard is measured perpendicular to the luff and shall not be larger than the value in Table IX.

6.6.1.2 (B). Measurement of the mainsail foot is taken from the after side of the mast, at the lower measurement band, along the top of the main boom to the forward edge of the main boom measurement band. If the measurement band is missing the measurement is taken to the boom end.

At the 15-40m² classes the after side of the mast is defined according to ISAF's regulations.

At the 55-150m² classes the after side of the mast is defined as that point in the midship plane which lies at a distance equal to the mast diameter (table value) aft of the front face of the mast. (Figure 18).

6.6.2 Triangle mainsail on a bent mast

If the after side of the mast not is straight, the mainsail hoist is measured in a straight line from the lower edge of the top measurement band at the after side of the mast to the top edge of the lower measurement band at the after side of the mast. When the top measurement band is missing the measurement is taken from the centre point of the sheave of the main halyard. Furthermore shall, by preference when the mast is lying, the distances Q₂ and Q₄ be measured from

the right line M perpendicular to the after side of the mast. Q₂ half way from the lower measurement band and Q₄ at ¾ from the lower measurement band.

6.6.3 Gaff mainsail

The following measurements are taken:

The mainsail hoist M

The mainsail foot B

The length along the gaff G

The diagonal from jaw to clew D

M. Measurement of the mainsail hoist is taken from the top edge of the lower measurement band along the after side of the mast to the lower edge of the top measurement band, above which the throat / claw shall not be hoisted.

B. Measured according to 6.6.1.2.

G. The length of the gaff is measured when the gaff is lying on the main boom, from the after side of the mast to the fore edge of a measurement band at the gaff end, or when the measurement band is missing to the gaff end. The after side of the mast is defined as in the B measurement.

D. The diagonal from throat / claw to clew is calculated through the formula $D = \sqrt{M^2 + B^2}$

6.6.4 Foretriangle

The following measurements are taken:

The foretriangle base J

Height of the foretriangle I

6.6.4.1 J. The base of the foretriangle J is measured from the fore side of the mast at a level of the upper side of the deck to the point where the centre line of the forestay meets the deck.

If the spinnaker halyard is the max height of the I measurement, this is to be measured according to the ISAF regulations.

6.6.4.2 I. The height of the foretriangle is measured on the fore side of the mast from that point where the highest foresail or spinnaker hoist is fixed to the mast to a point 1/25 of the beam above the covering board. When the sail is fitted to the forestay, I is measured to the point where the rear edge of the stay or its extension meets the fore side of the mast.

6.6.4.3 Spinnaker pole

The spinnaker pole is to be measured from its outermost end including all fittings, to the front face of the mast in the midship plane, and to the centreline of the mast when the spinnaker pole is in the athwartship position. If either measurement exceeds the foretriangle base, then the greatest measurement shall be used to calculate the foretriangle area. (Figure 23)

When the mast is rotating the athwartships measurement shall be taken with the mast turned 45°. The regulations for the spinnaker headboard are the same as for the mainsail headboard.

6.6.4.4 Fitting of spinnaker halyard

No arrangement to bring forward the spinnaker halyard front of the mast more than 1 / 3 of head board measurement value.

To control the measurement the spinnaker halyard is held sideways perpendicular to the mast. The measurement shall be taken between the front of the mast and the rear edge of the halyard can be measured.

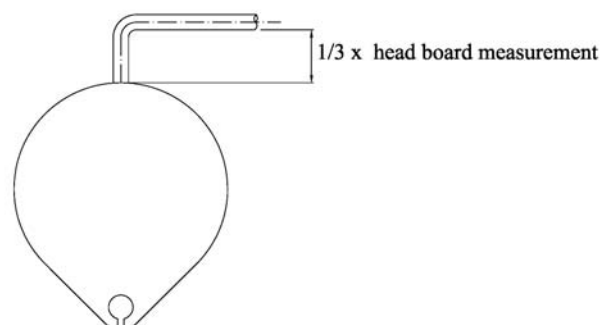

Figure 17 (Spinnaker halyard)

6.7 CALCULATIONS OF THE SAIL AREAS

6.7.1 Triangle mainsail on a straight mast

$$\text{Area} = \frac{M \times B}{2}$$

6.7.2 Triangle mainsail on a bent mast

$$\text{Area} = \frac{M \times B}{2} + \frac{5 \times M \times Q_2}{12} + \frac{M \times Q_4}{3}$$

6.7.3 Gaff mainsail

$$\text{Area} = \frac{M \times B}{2} + \frac{D \times G}{2}$$

6.7.4 Additional area on bent spars.

When a spar is bent between the measuring points, the received area shall be calculated as: $\text{Area} = \frac{2 \times M \times Q}{3}$

6.7.5 Additional area of boom height.

When the boom has a height larger than the table value for a hollow wooden mast, the additional height shall be included in the measurement M.

6.7.6 Foretriangle

$$\text{Area} = \frac{J \times I}{2}$$

The foretriangle includes 85 % of its area in the sail area of the yacht: S.

6.7.7 Forestay profiles

I and J are measured to the points where the rotation axis of the luff groove device meet the deck and the mast. To the received area of the fore triangle is the area of the luff groove device which lies forward of the rotation axis added. (Figure 25).

6.7.8 Unusual sail shapes.

The regulations of main sail measuring are intended to ensure that the calculated area shall be as close to the real area in the sail plan as possible. When unusual sail shapes are used the Classifying Board may issue additional instructions, which have to be reported to the Swedish Sailing Federation as soon as possible.

6.8 SAIL MEASUREMENT

The sails may be produced in any material and with any type of reinforcements.

Foresails and spinnaker are free in shape and area and could be carried with or without spinnaker pole.

When sails are measured the ISAF Equipment rules shall be applied.

6.8.1 Restrictions of foresails for the 15 and 22 m²-classes

The 15 and 22 square metre classes have following restrictions:

Besides mainsail only foresails and spinnakers are permitted to be carried.

Foresail half width shall not exceed 0,5 times the length of the foot.

The maximum width of the spinnaker (SMV) shall be at least 0,75 times the length of the foot, the sail shall be symmetric to its centre.

6.8.2 Mainsail width restrictions

The width of the mainsail at $\frac{1}{4}$ of the height shall not exceed B₁ according to Table IX. To this length any Q₁ may be added.

The width of the mainsail at half the height shall not exceed B₂ according to Table IX. To this length any Q₂ may be added.

The width of the mainsail at $\frac{3}{4}$ of the height shall not exceed B₄ according to Table IX. To this length any Q₄ may be added.

The sail may not extend aft of a straight line between the top batten and the aft head point.

The $\frac{1}{4}$, $\frac{1}{2}$, and the $\frac{3}{4}$ widths shall be measured according to the ISAF Equipment rules of sailing.

6.8.3 Battens

Yachts in the classes 15-40 m² shall have 4 battens, dividing the leach into 5 equal sections. The tolerance is +/- 0.5 x the headboard value. The batten lengths are free.

Yachts in the 55-150 m² classes may have free battens which are free in length and number, or have regulated battens according to Table IX.

6.9 Table IX SAILS

Sail area (S)	at most	m ²	Class sqm.								
			15	22	30	40	55	75	95	120	150
Headboard of mainsail and spinnaker, side length	at most	m	0.10	0.11	0.12	0.14	0.16	0.18	0.20	0.22	0.24
Regulated battens											
Number (dividing aft leach into 5 equal sections)	at most						4	4	4	4	4
Length of each of the central battens	at most	m					1.30	1.45	1.60	1.75	1.80
Length of the highest and lowest battens	"	m					1.00	1.10	1.20	1.31	1.35
The width of the mainsail B ₁ at $\frac{1}{4}$ height of M in % of B	at most	%					86	86	86	86	86
The width of the mainsail B ₂ at half height of M in % of B	at most	%					62	62	62	62	62
The width of the mainsail B ₄ at $\frac{3}{4}$ height of M in % of B	at most	%					39	39	39	39	39
Free battens											
Number (dividing aft leach into 5 equal sections)	at most		4	4	4	4					
The width of the mainsail B ₁ at $\frac{1}{4}$ height of M in % of B	at most	%	89	88	87	86	86	86	86	86	86
The width of the mainsail B ₂ at half height of M in % of B	at most	%	70	68	67	62	62	62	62	62	62
The width of the mainsail B ₄ at $\frac{3}{4}$ height of M in % of B	at most	%	44	43	42	39	36	36	36	36	36

¹The maximum top width is: headboard (table value) + 30mm.

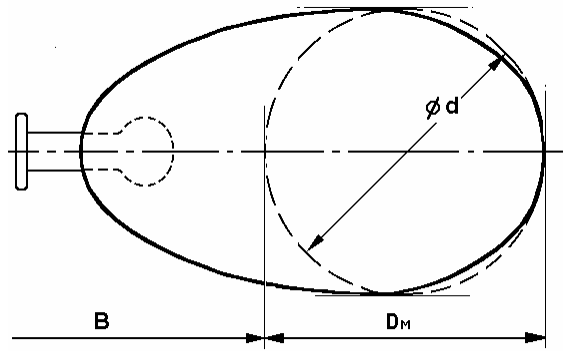

Figure 18 (Measuring the length of the boom at 55-150 sqm)

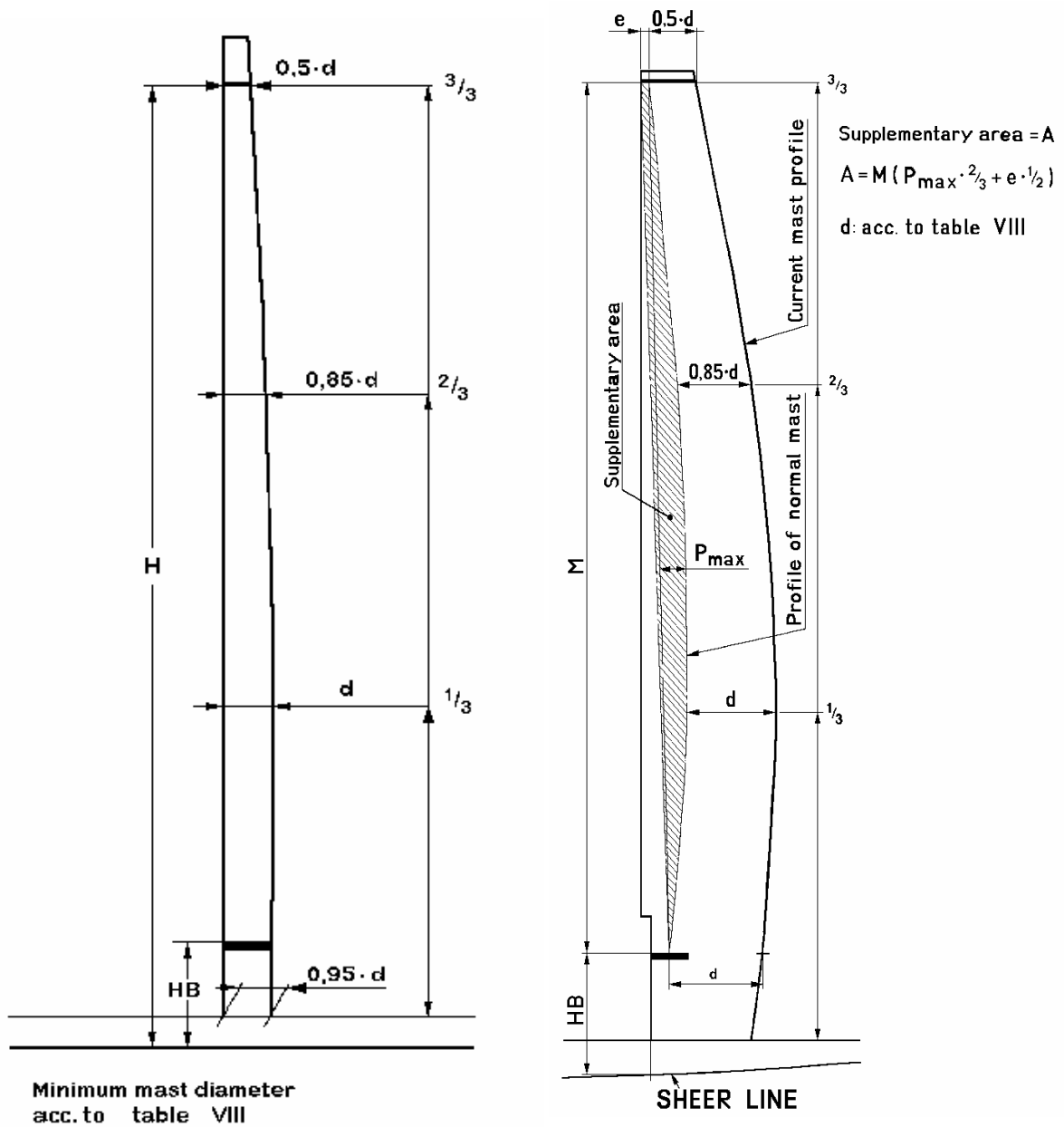

Figure 19 (Mast diameters) at 55-150 sqm)

Figure 20 (Supplementary area for flat rotating mast at 55-150 sqm)

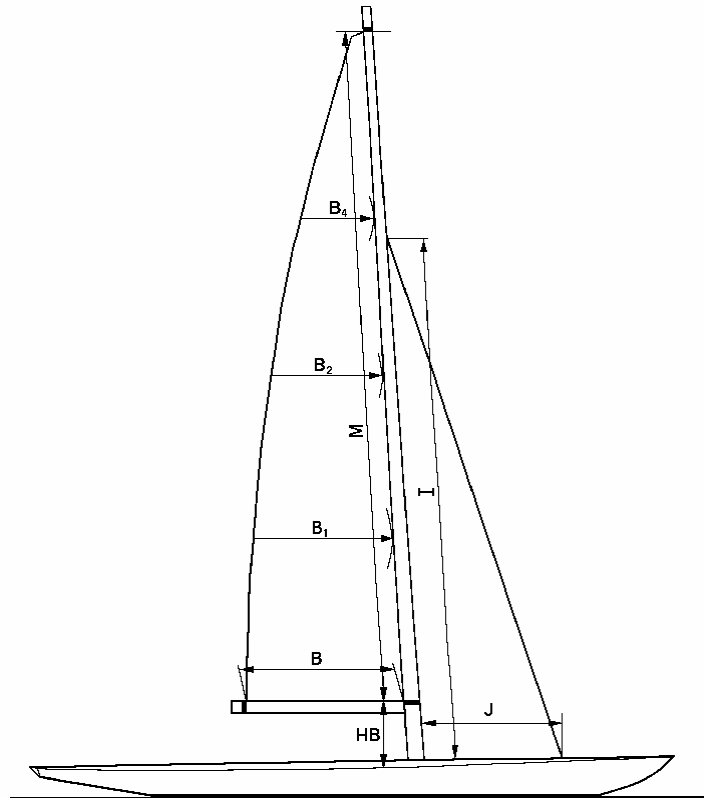

Figure 21 (Triangular mainsail with straight mast)

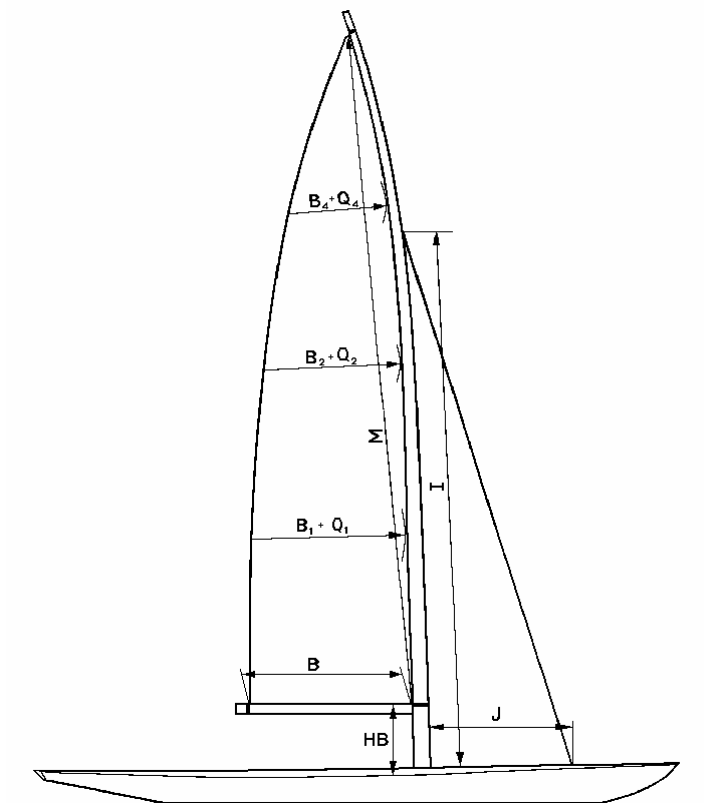

Figure 22 (Triangular mainsail with bent mast)

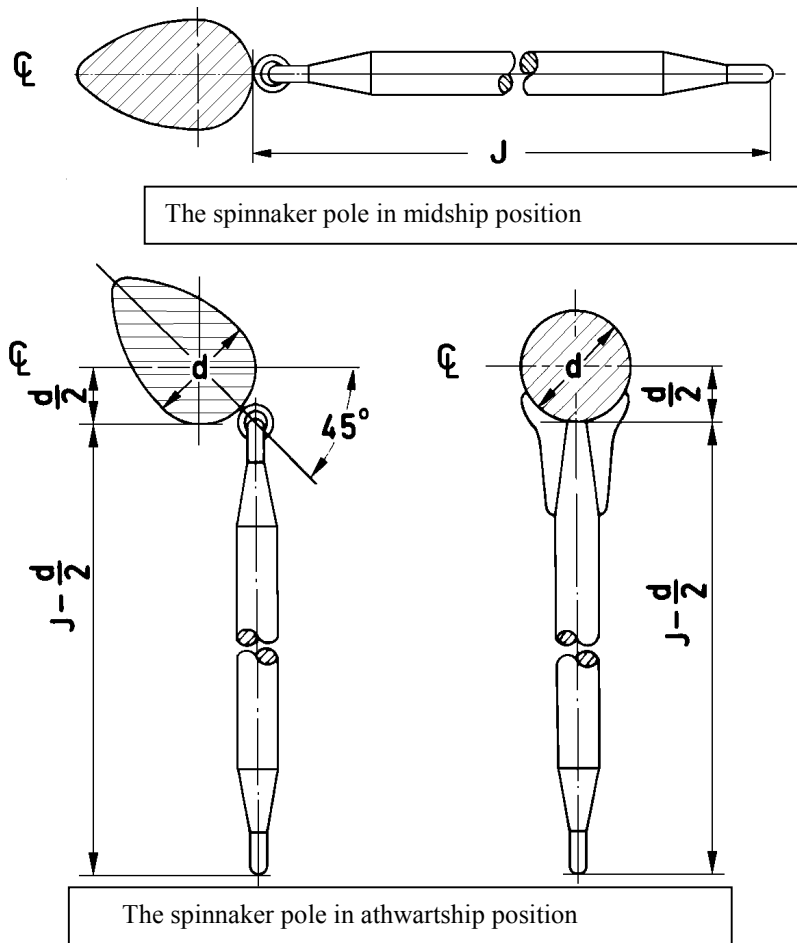

Figure 23 (Spinnaker pole)

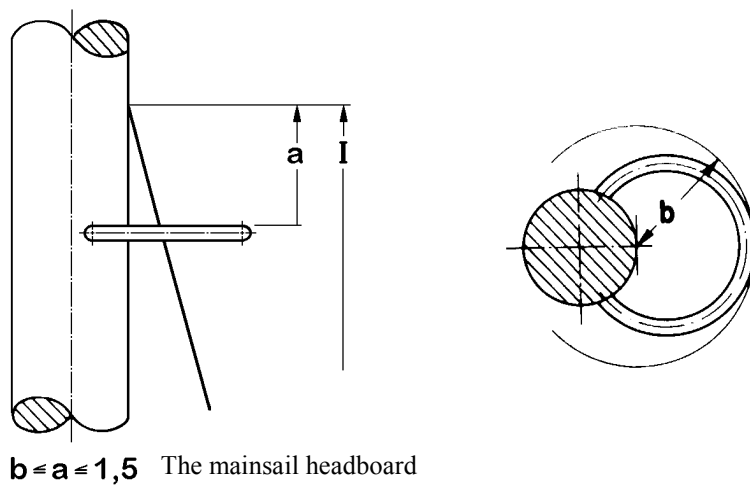

Figure 24 (Spinnaker loop)

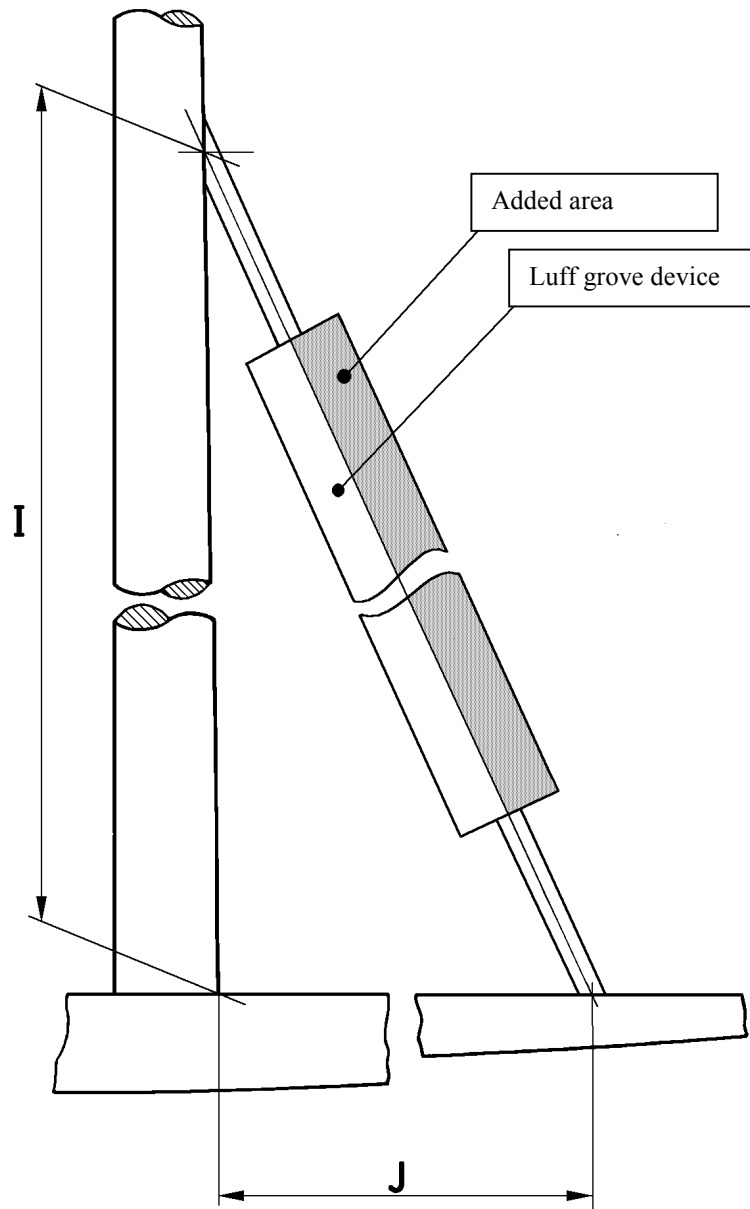

Figure 25 (Luff groove devices)

Index

A

a₁ vertical plane 1	5
a₂ vertical plane 2	5
anchor	8
anchor capstan	8
anchor chain	8
anchor rope	8

B

B bow width horizontal plane 1	6
B₁ width	43
B₂ width	43
B₄ width	43
ballast keel	26
beam clamp	13, 16
bent mast	41
berths	8
b_g gangway width	8
bilge stringer	16
bm mean breadth	6, 7
bolts	14, 20
bow width (B)	6
b_r width of cabin	8
bulk-heads	8

C

cabin	9, 16
cabin internal height (h₃)	40
cabin length (l_r)	40
cabin roof	16
cabin width (b_r)	40
cabinet	8
centre-board	12
certificate and surveys	10
classification	10
coaming	16
coaming height	8, 40
cockpit area	8, 40
construction under survey	11, 21
counter frames	18
covering board	16
crew	8

D

d diameter of mast	34
D gaff, diagonal measurement	41
deck	14, 16
deck beam	13, 19
deck camber	7
deck flange	25, 28
deck, plastic	28
detail design, plastic	23
diameter of alum. mast (d)	34
diameter of mast (d)	34
dimensions, plastic	28
displacement control	37
displacement (W)	5, 7

E

equipment	8
execution of the work, plastic	22

F

F freeboard	5
F freeboard	7
F_a freeboard aft	5
F_f freeboard fore	5
floor, plastic	24, 28
floorboards	8
floors	17, 18
foretriangle	41, 42
frame spacing	17
frames	17, 18
freeboard (F)	5, 7, 38
furnishing	8

G

gaff sail	41
gaff, diagonal measurement (D)	41
gangway width (b_g)	8, 40
gelcoat	24

H

H sail plan height	30
h₁ minimum of height in vp1	5
h₂ minimum of height in vp2	5
h₃ height of cabin	8
height of cabin (h₃)	8
height of sail plan (H)	34
horizontal knees	19
horizontal plane 1	5
horn timber	11, 16

I

ideal length (L)	5
ideal length (L _x)	38

K

K length of keel	5
K length of keel	7
keel	11, 16
keel length (K)	38
keel marks	36
keel sole, plastic	28
keel strake / keel sole	24
keel strake, plastic	28
knees	13

L

laminate testing	24
length in horizontal plane 0 (L ₀)	38
length of cabin (l_r)	8
length of keel (K)	5, 7
l_r length of cabin	8
L_x ideal length	7

M			
main section	36	self-bailing	8
manufacturing standards	22	skerry boats	9
marking nails	36	spinnaker pole	42
marking screws	36	sternpost	11, 12, 16
mast	6, 34	sum of the freeboards (F_r+F_a)	5
mast foot	11, 12	surveyal plastic	21
mast support, plastic	26	T	
material in wooden boats	11	t thickness of laminate	28
mean breadth (bm)	5, 6, 7, 38	Table I	5
mean section	5	Table II	8
measurers	35	Table III	16
measuring instruments	35	Table IVa	17
minimum height in vp1 (h_1)	38	Table IVb	18
minimum height in vp2 (h_2)	38	Table V	19
minimum of height in vp1 (h_1)	5	Table VI	20
minimum of height in vp2 (h_2)	5	Table VII	28
modulus of elasticity, plastic	24	Table VIII	34
O		thickness of laminate (t)	28
official appeal	35	to small weight of the deck, plastic	26
P		to small weight of the hull, plastic	26
panel weight, plastic	28	toalet	8
planking	14, 16	towing rope	8
planking thickness	16	transverse frames, plastic	28
pump	8	trim marks	36, 39
R		trimming and floating	7
rabbit	16	U	
rigging drawing	10	ultimate flexural strength, plastic	24
rivets	14, 20	ultimate tensile strength, plastic	24
rudder	11, 12	V, W	
rudder stock	16	W displacement	5, 7
S		water cisterns	8
S sail areas	42	weight aluminium mast	32
sail areas (S)	42	vertical knee	19
sail plane height (H)	30	vertical plane 1 (a_1)	5, 38
screwed joints, plastic	23	vertical plane 2 (a_2)	5, 38
screws	14, 20	width (B_2)	43
		width (B_4)	43
		width of cabin (b_r)	8